

CIRCUIT BLOCK DIAGRAM

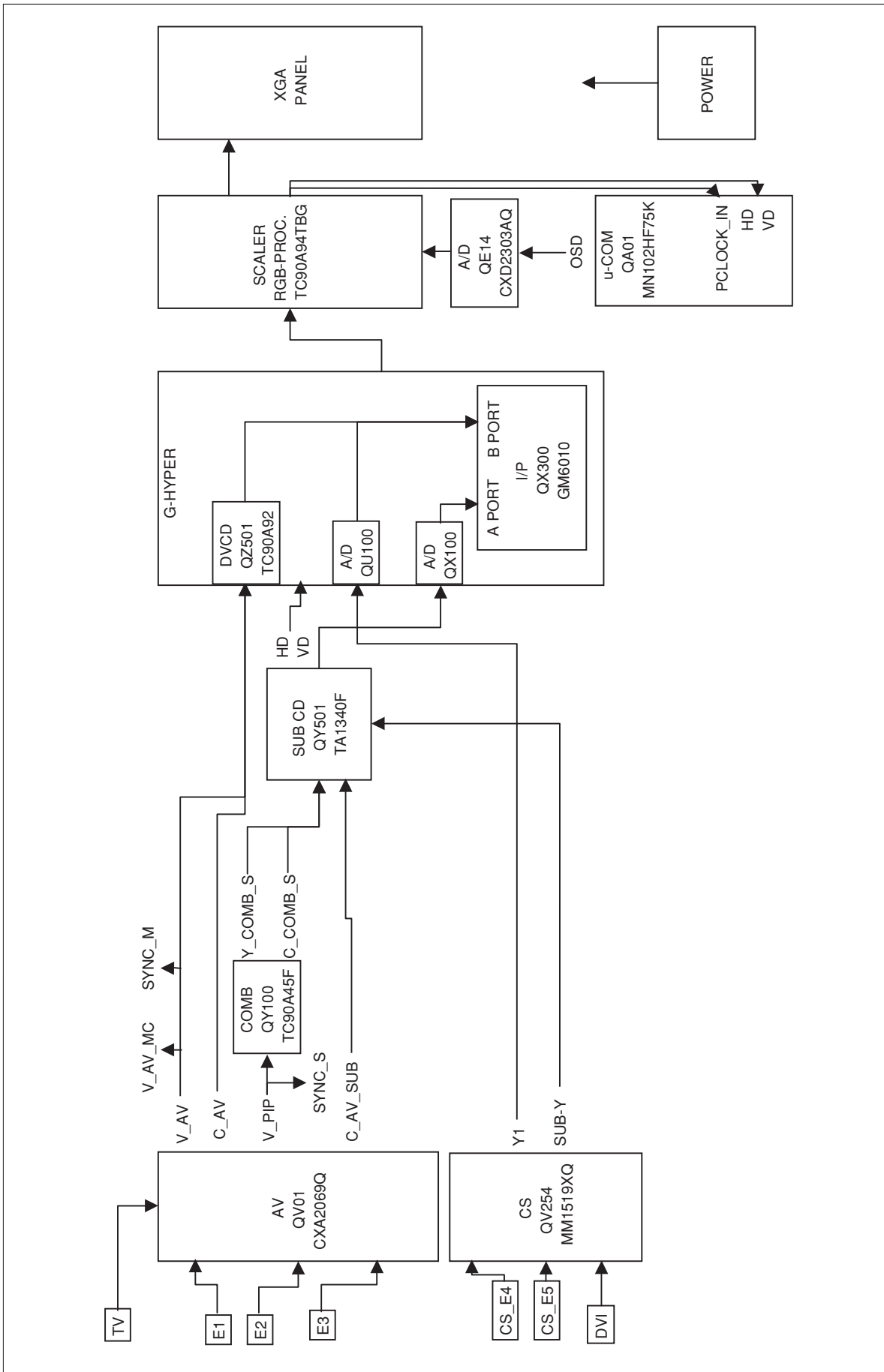

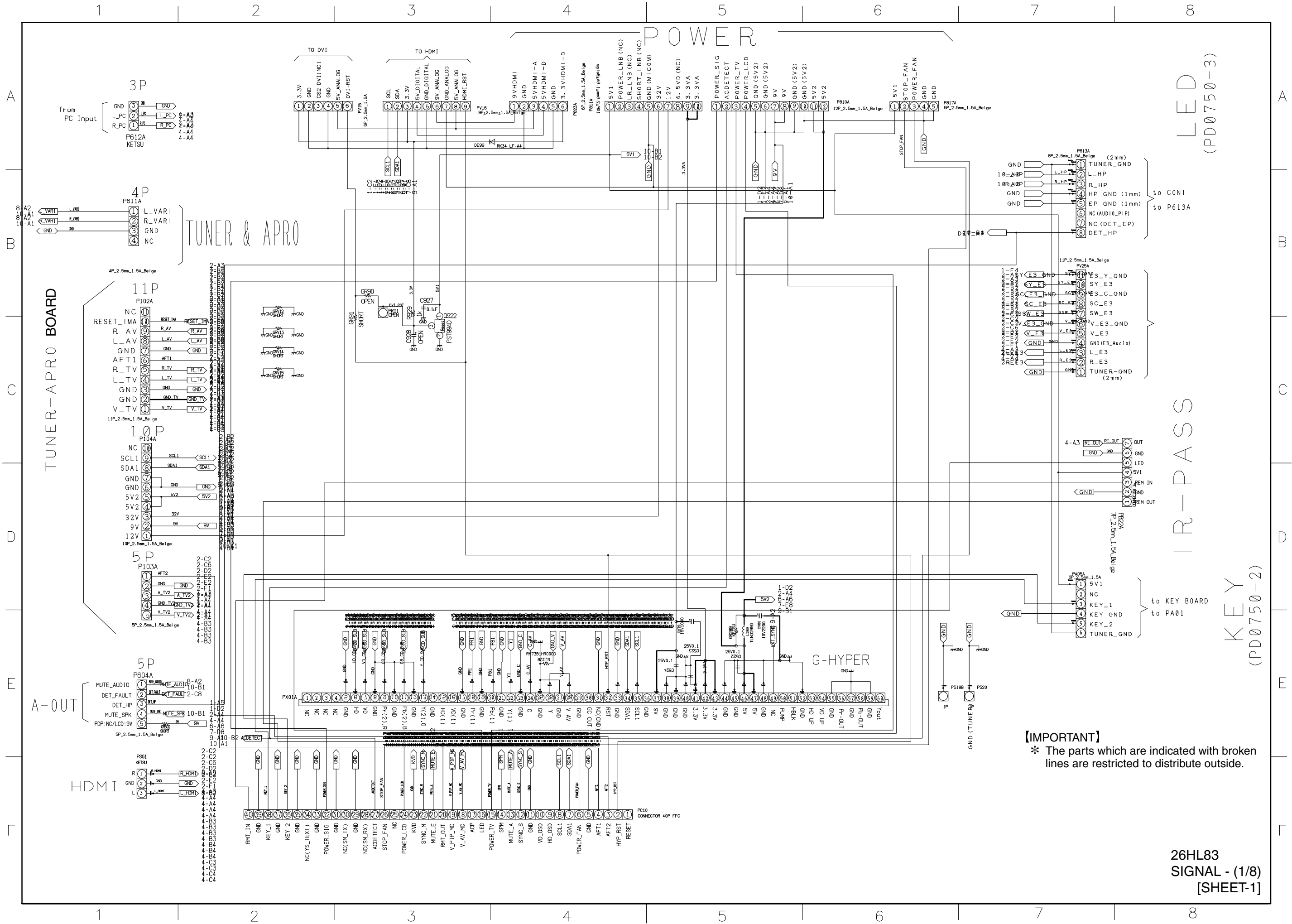

[IMPORTANT]
 * The parts which are indicated with broken lines are restricted to distribute outside.

A

B

C

D

E

F

1

2

3

4

TUNER-APRO BOARD

A-OUT

HDMI

TUNER & APRO

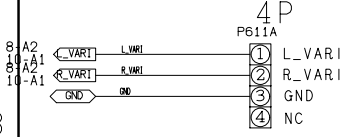
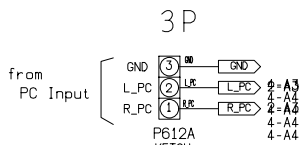

4P_2.5mm_1.5A_Beige

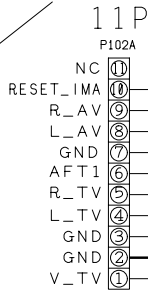

11P_2.5mm_1.5A_Beige

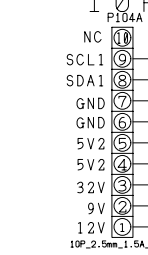

10P_2.5mm_1.5A_Beige

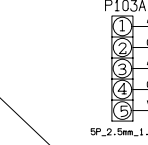

5P_2.5mm_1.5A_Beige

5P P604A

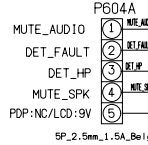

5P_2.5mm_1.5A_Beige

PS01 KETSU

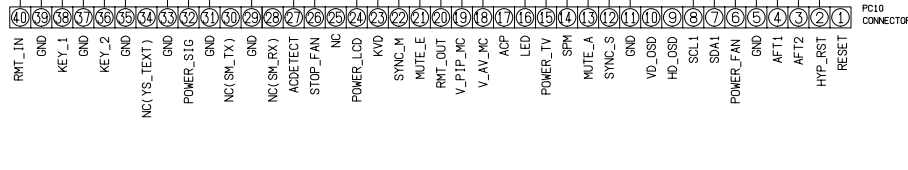
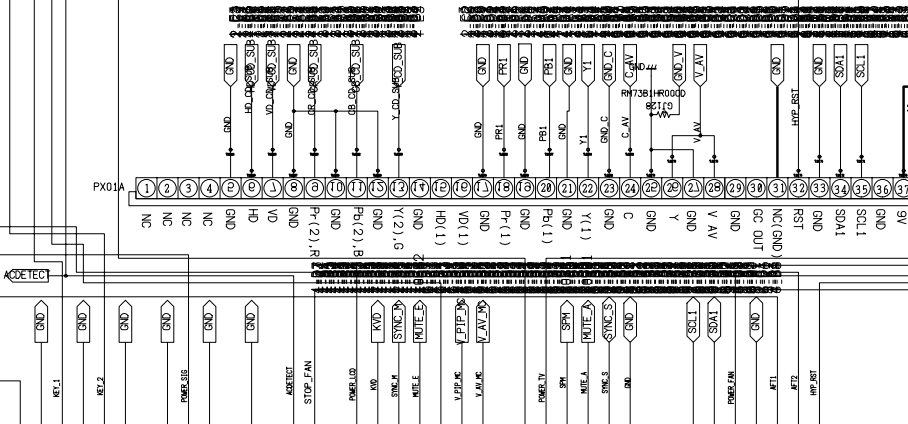
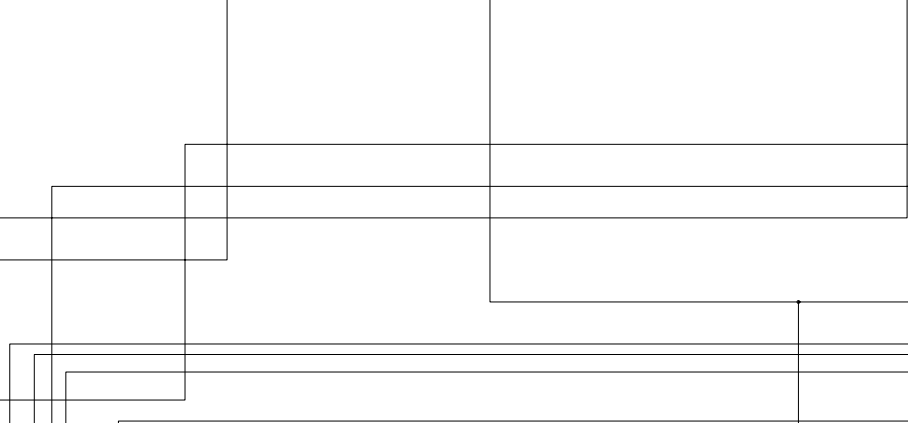
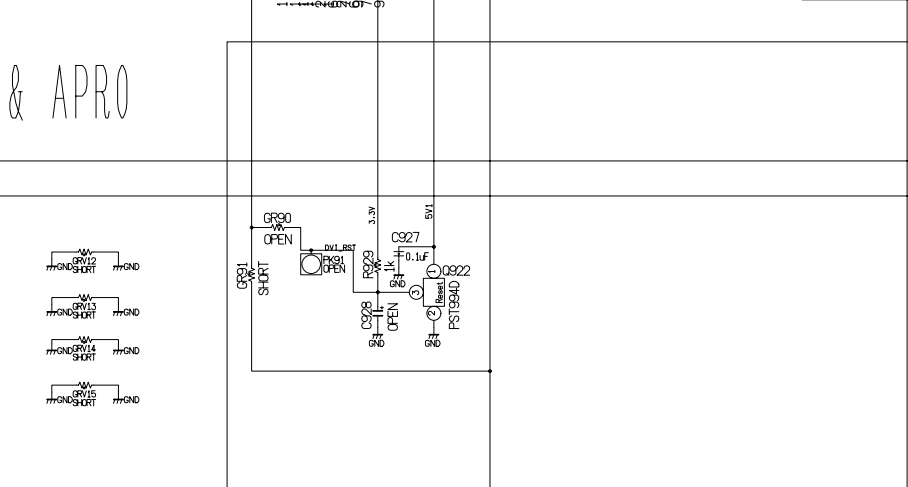
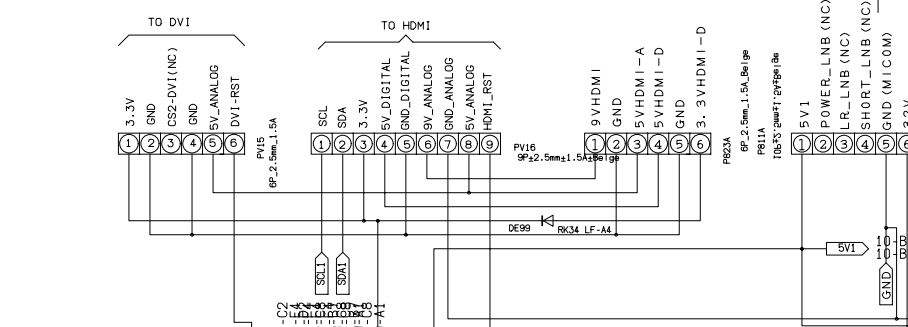
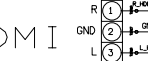

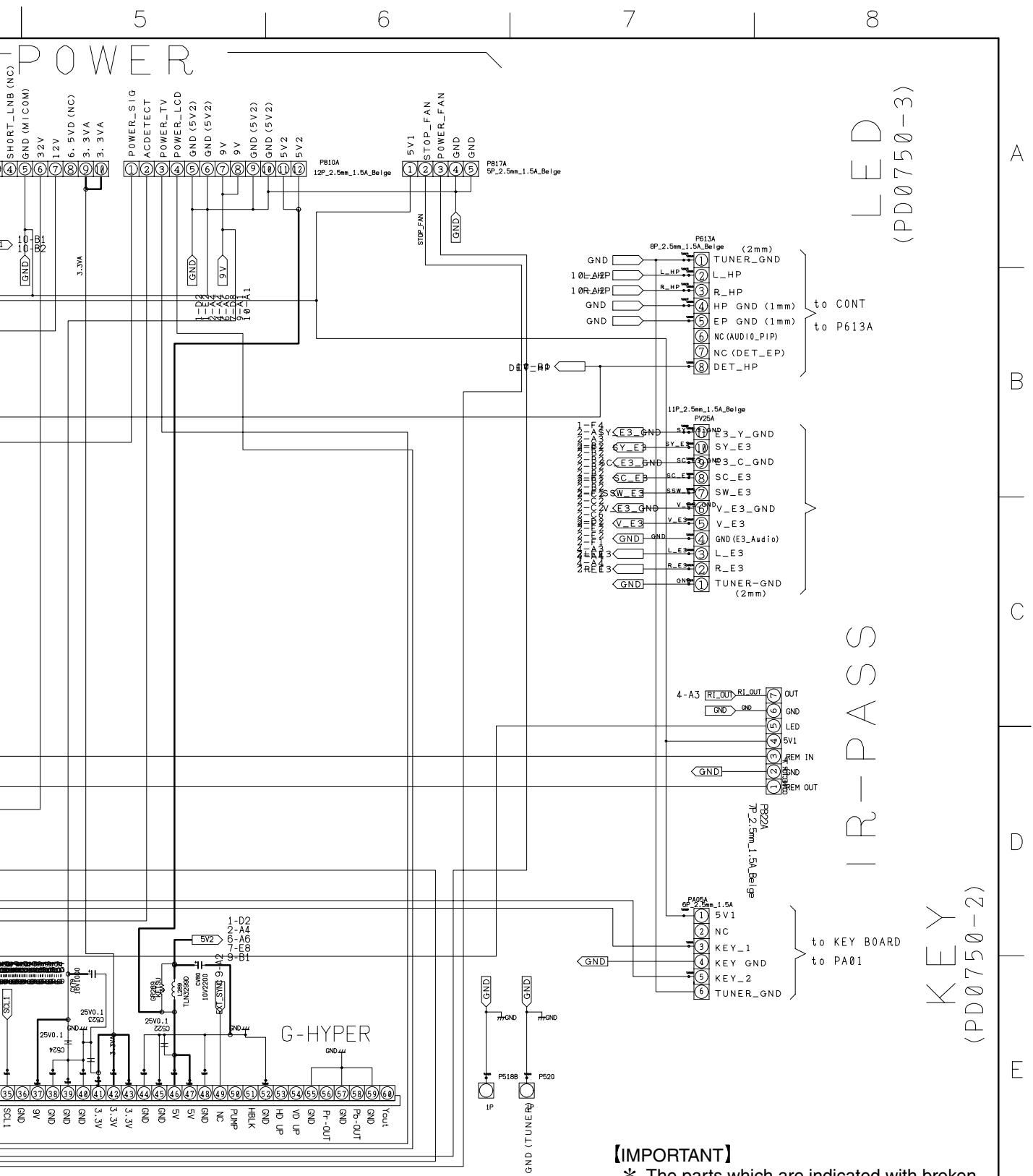

[IMPORTANT]
 * The parts which are indicated with broken lines are restricted to distribute outside.

PC10
 CONNECTOR 40P FFC

A

B

C

D

E

F

A

B

C

D

E

F

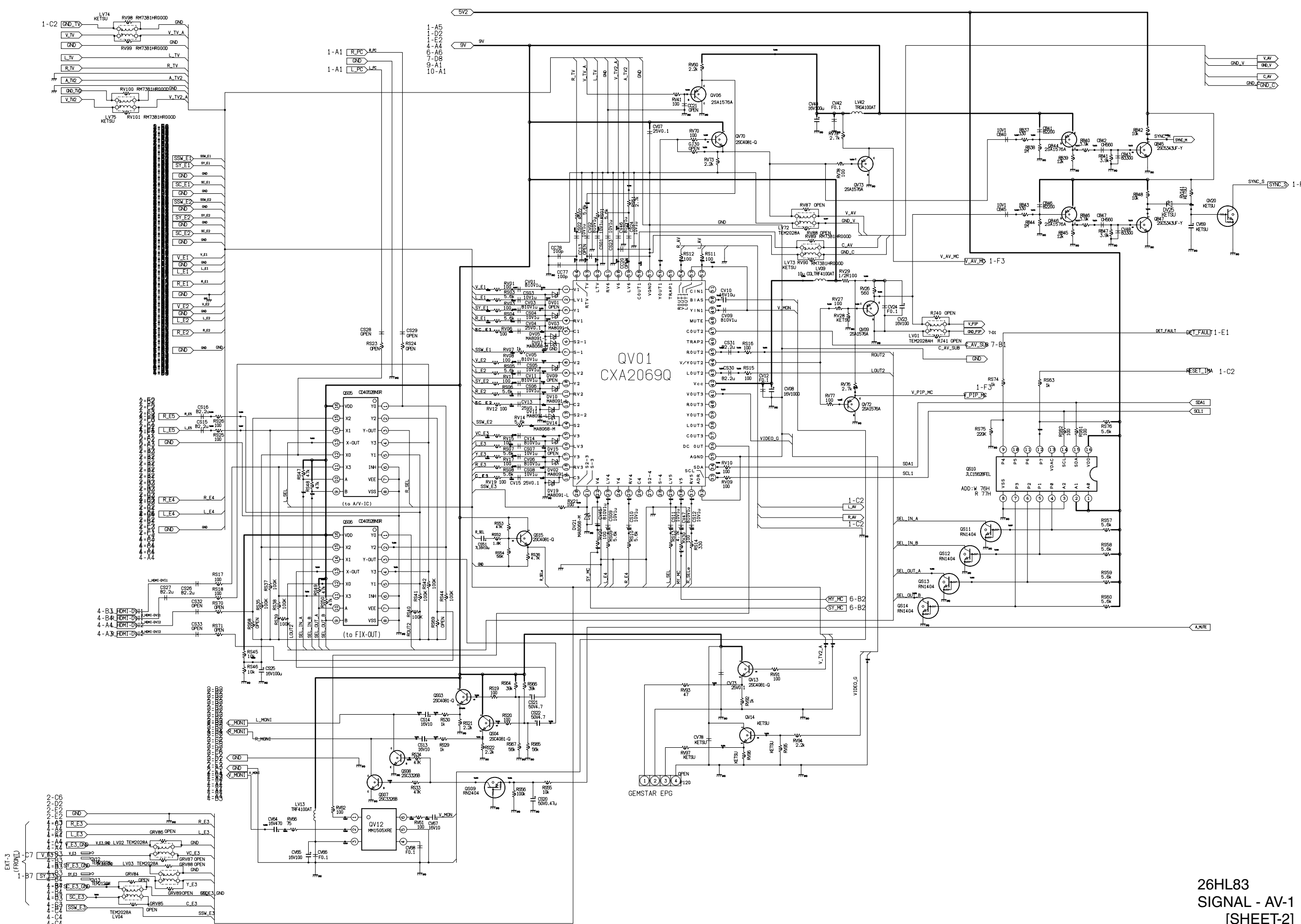

1

2

3

4

5

6

7

8

A

B

C

D

E

F

A

B

C

D

E

F

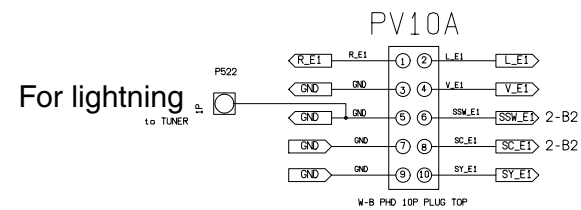
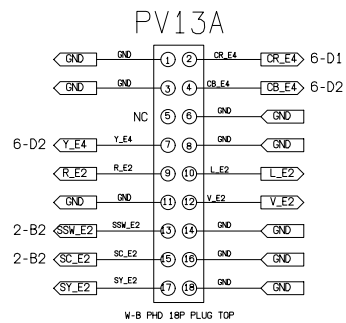
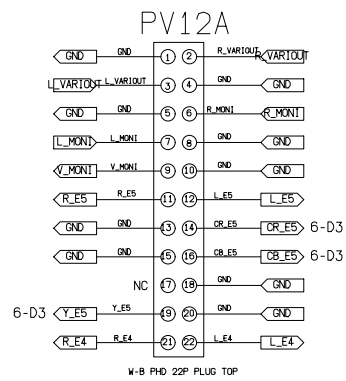
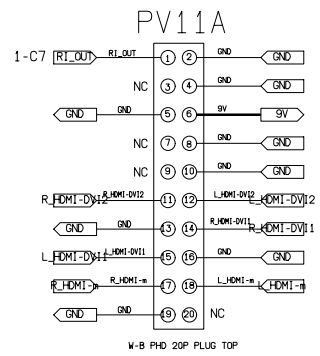

A

B

C

D

E

F

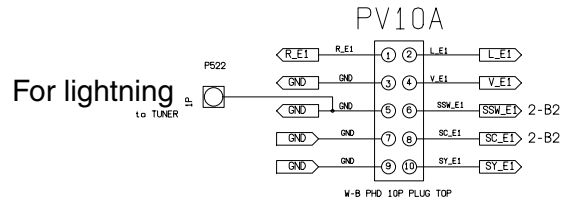
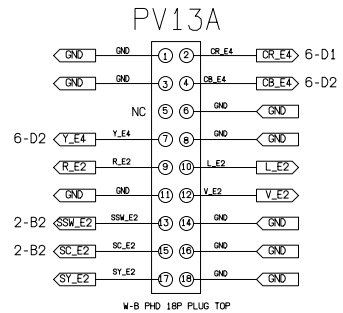
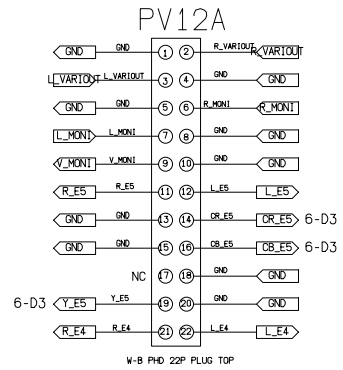
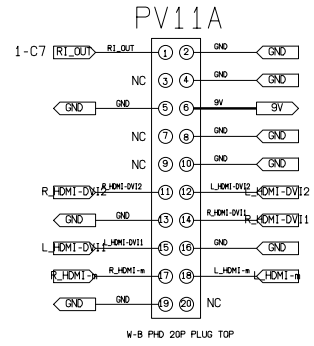

5

6

7

8

A

B

C

D

E

F

26HL83
SIGNAL - vs.AV
[SHEET-4]

5

6

7

8

A

B

C

D

E

F

1

2

3

4

5

6

7

8

A

B

C

D

E

F

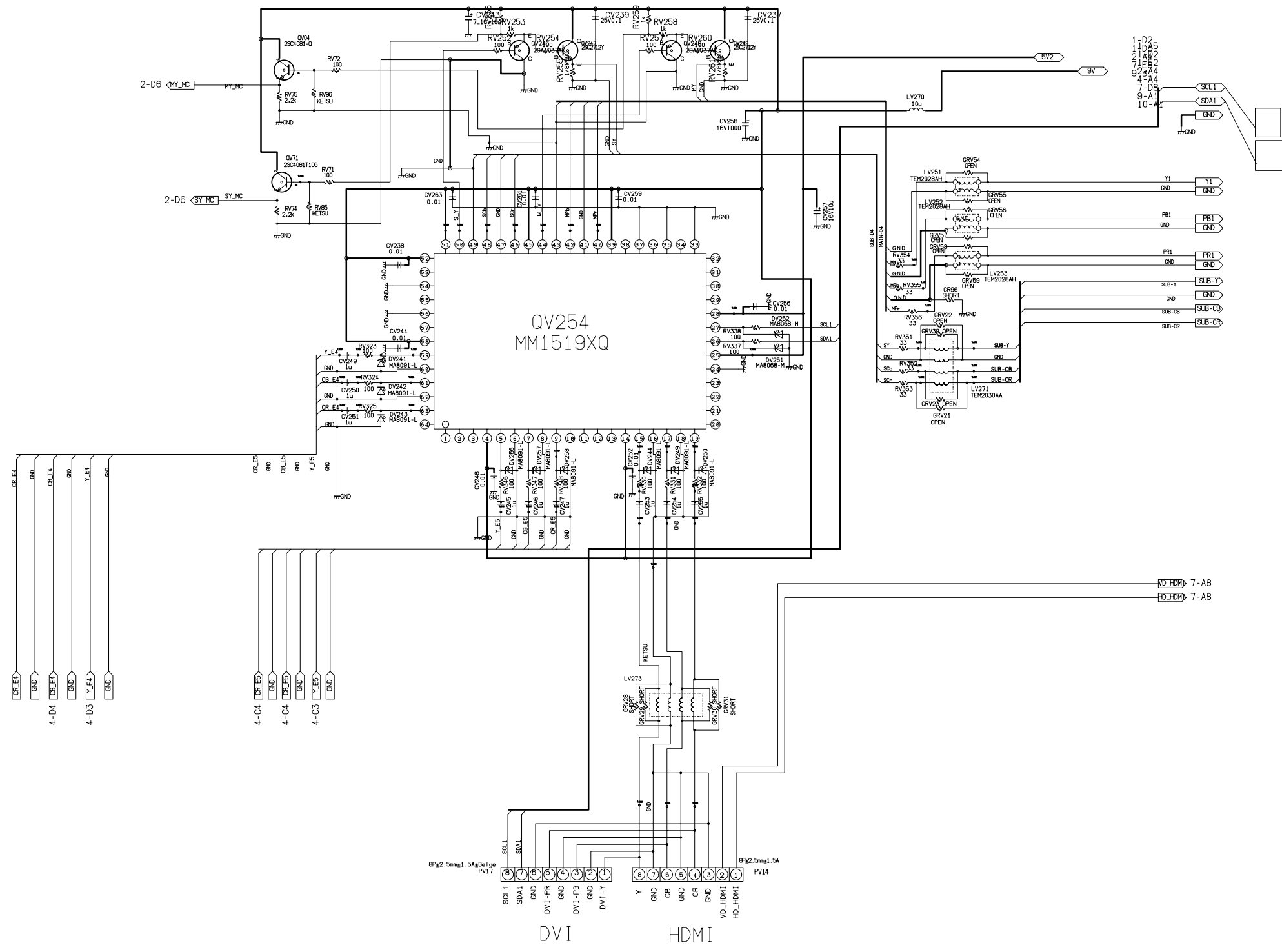

1

2

3

4

A

B

C

D

E

F

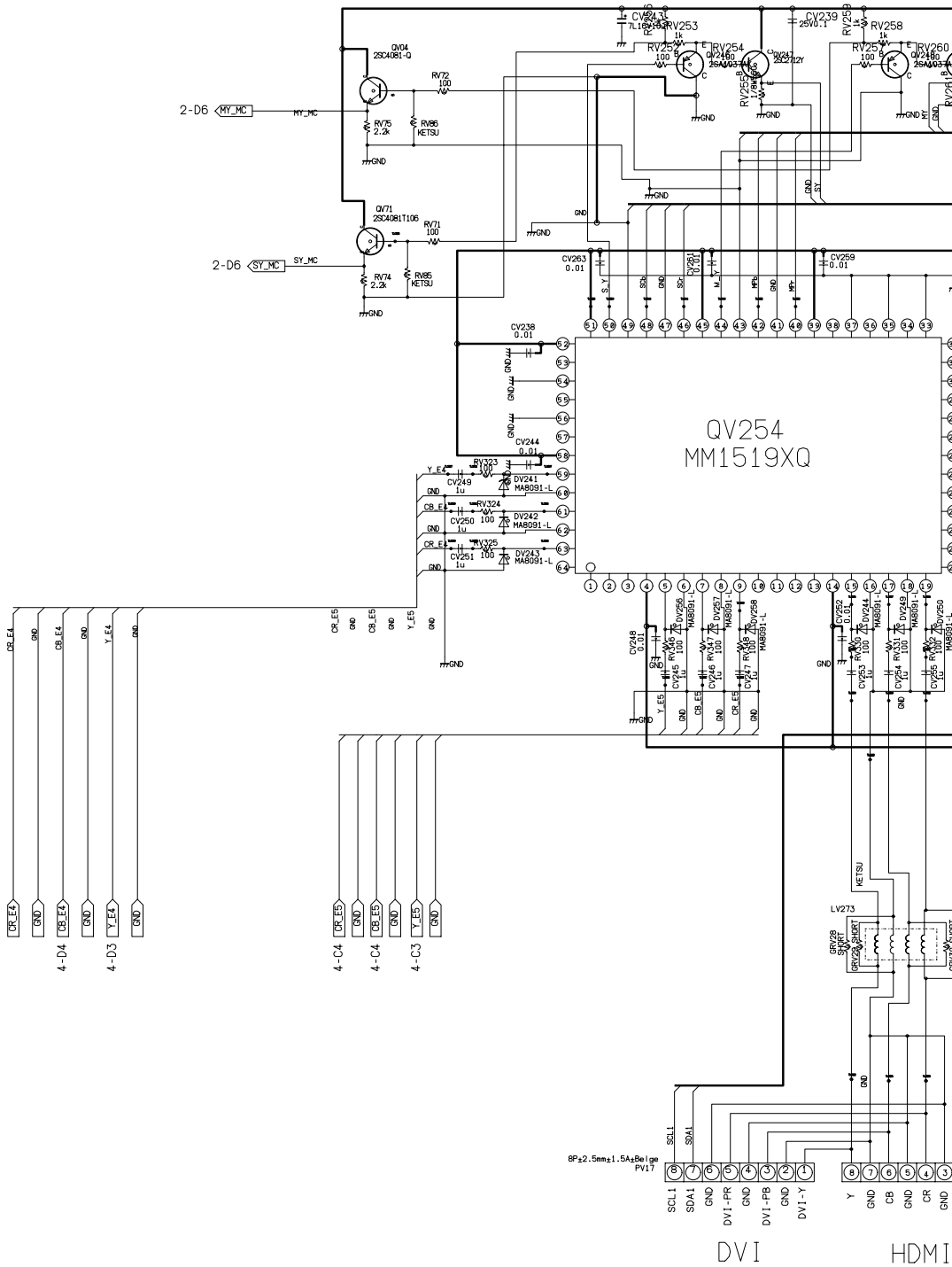

1

2

3

4

5

6

7

8

A

B

C

D

E

F

A

B

C

D

E

F

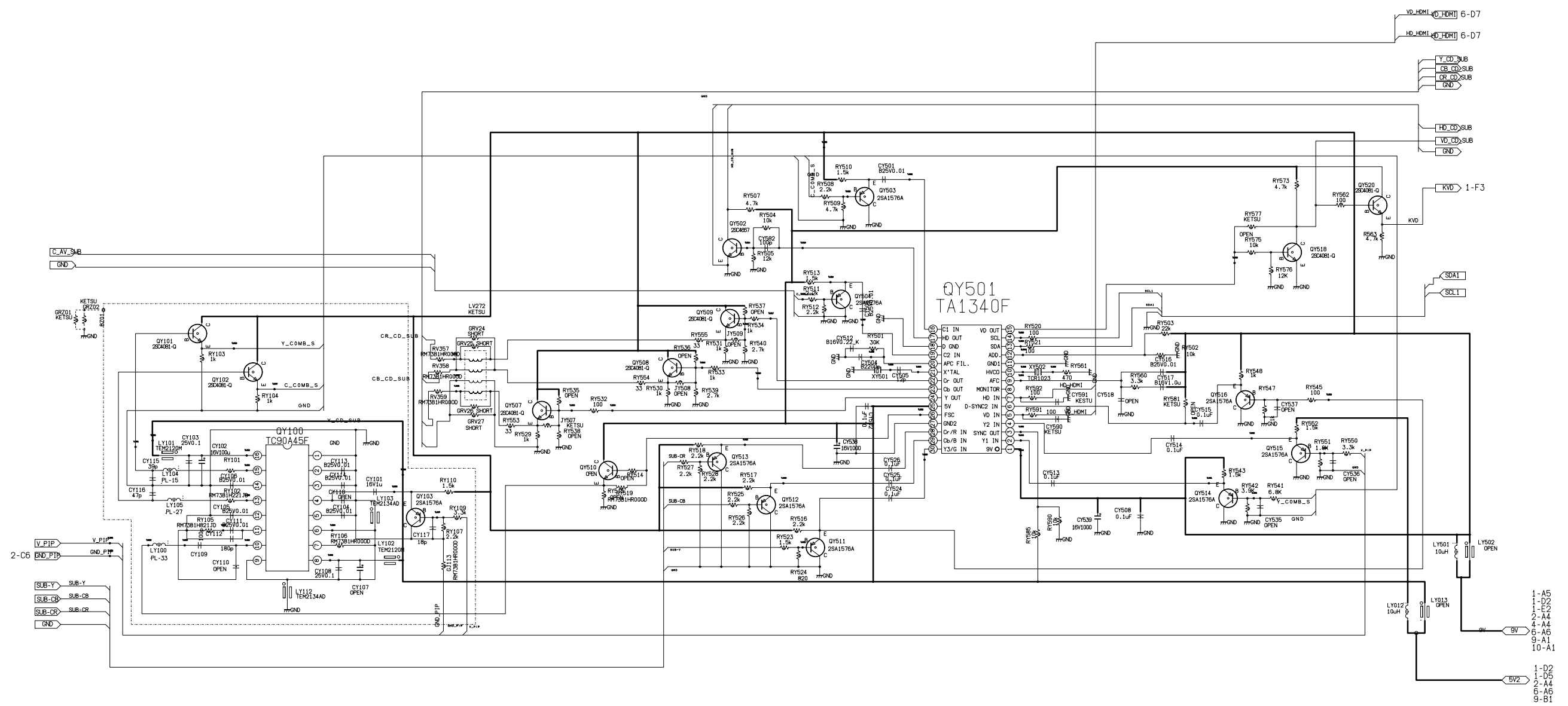

26HL83
 SIGNAL - AV-3
 [SHEET-7]

1

2

3

4

5

6

7

8

1

2

3

4

A

B

C

D

E

F

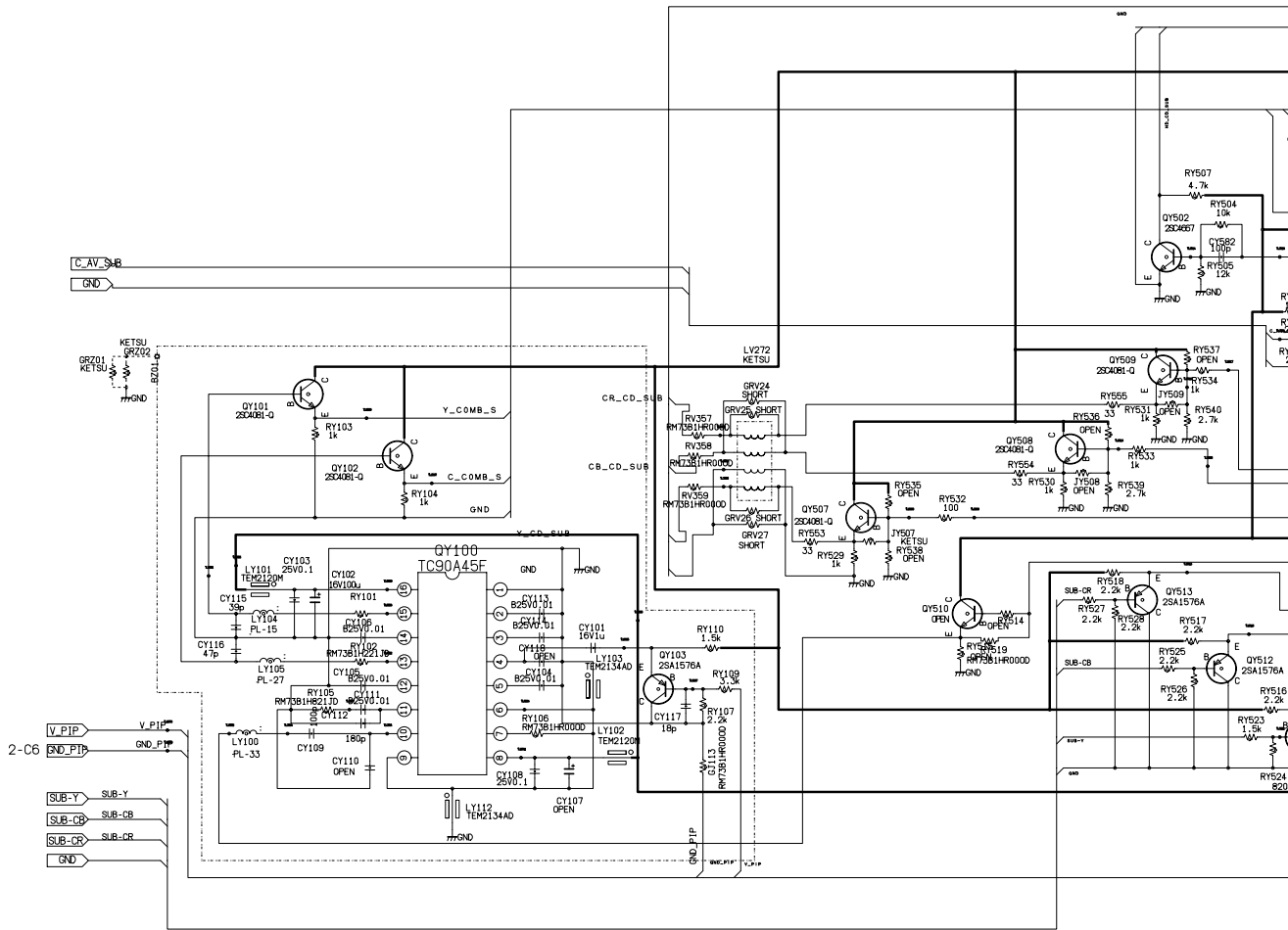

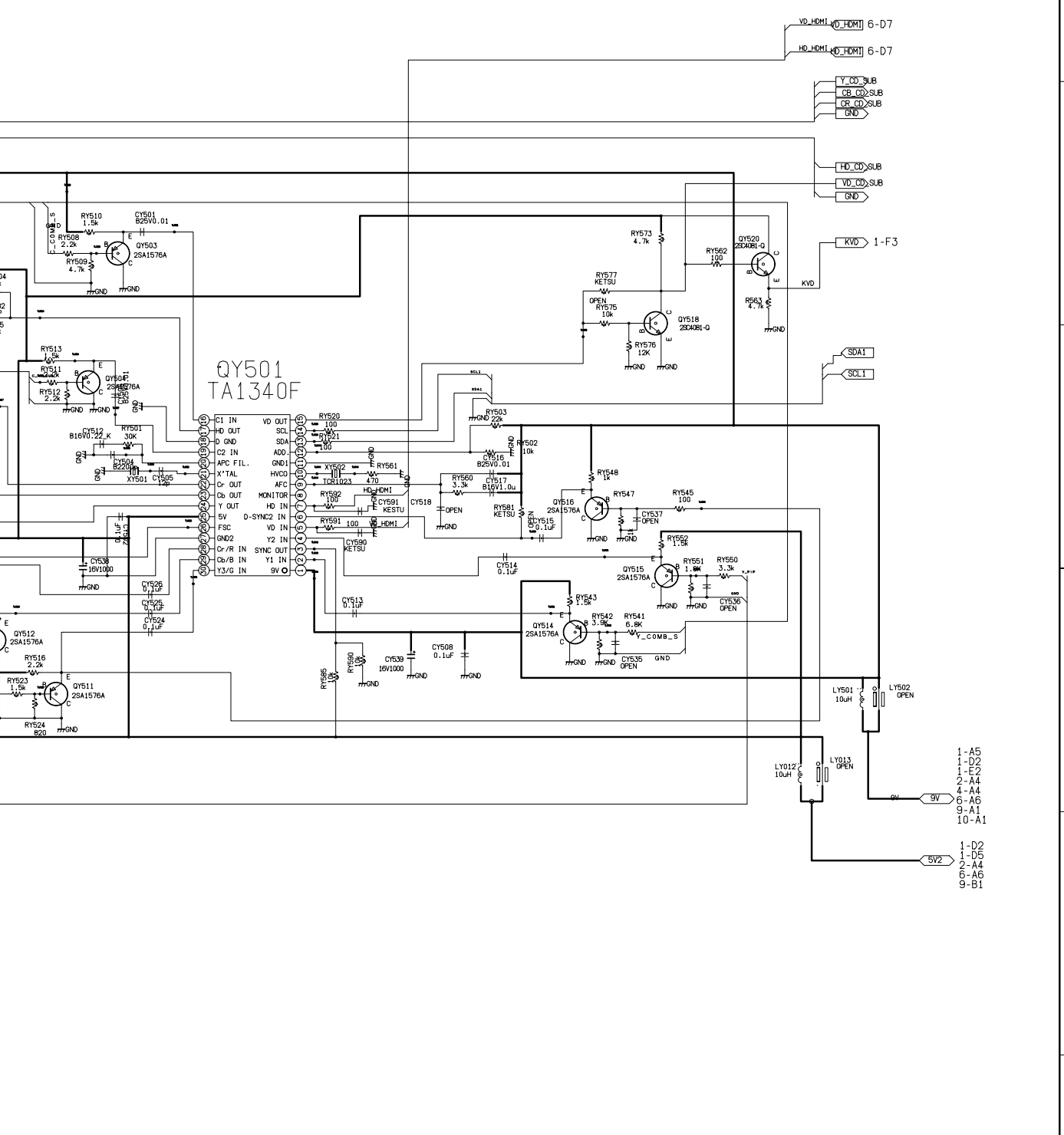

QY501
TA1340F

- 1-A5
- 1-D2
- 1-E2
- 2-A4
- 4-A4
- 6-A6
- 9-A1
- 10-A1

- 1-D2
- 1-D5
- 2-A4
- 6-A6
- 9-B1

26HL83
SIGNAL - AV-3
[SHEET-7]

1

2

A

A

B

B

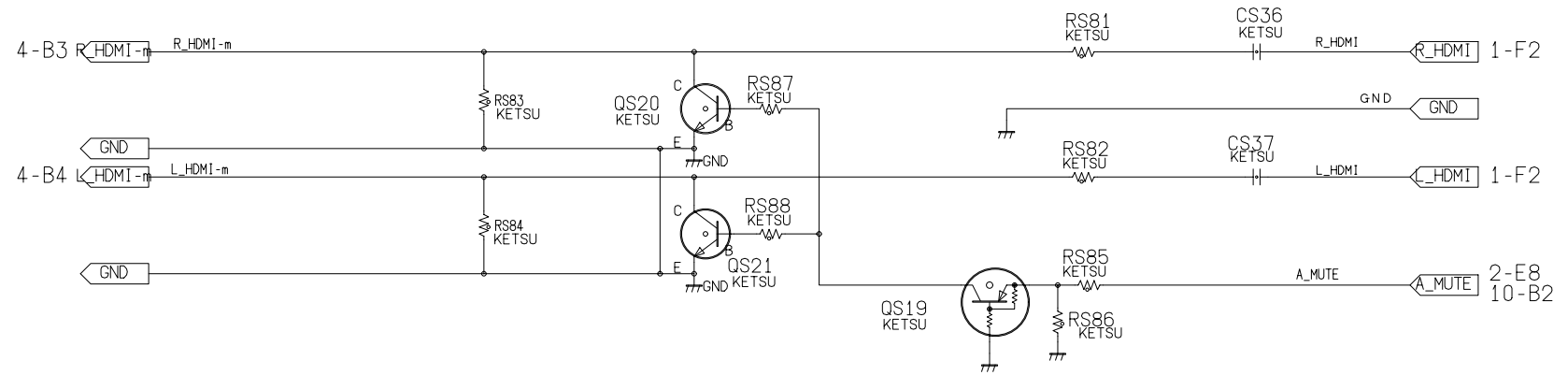
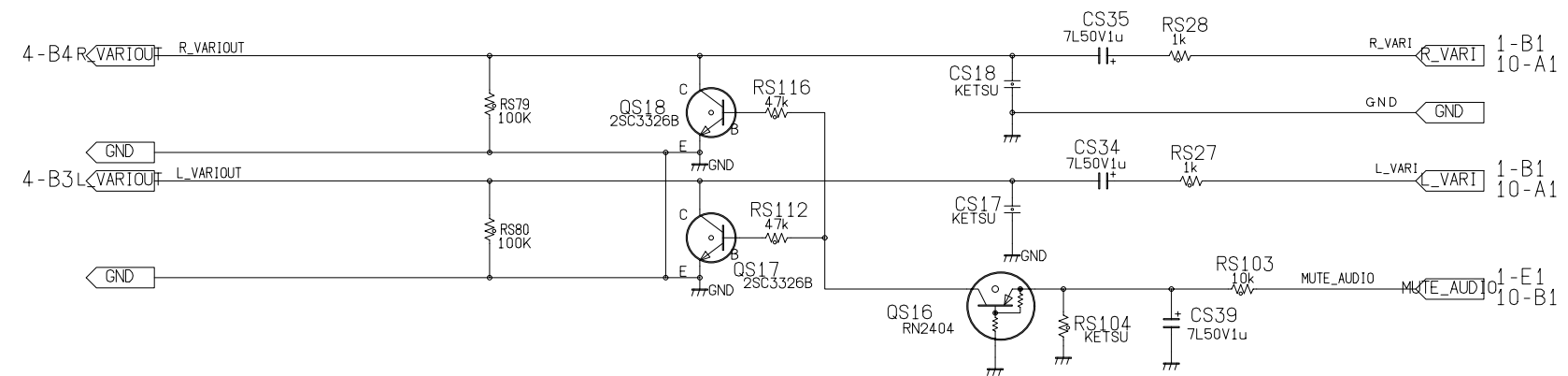

1

2

A

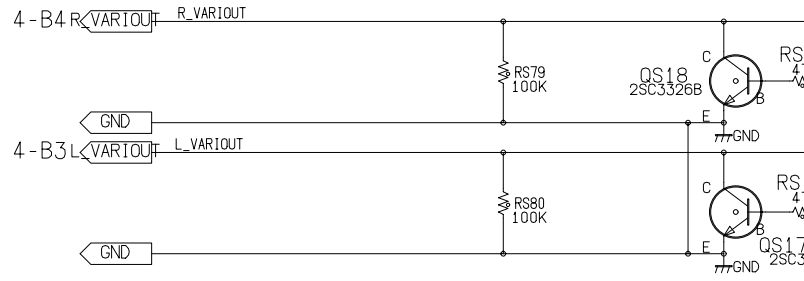

B

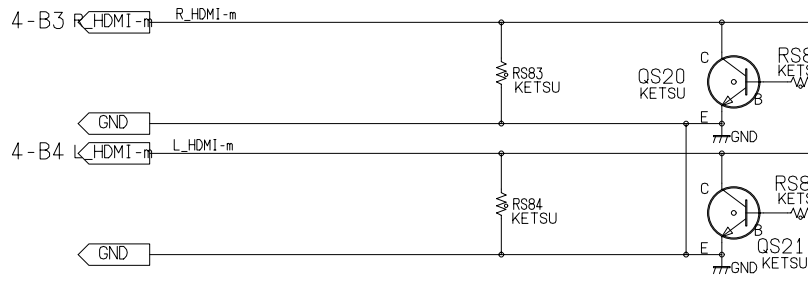

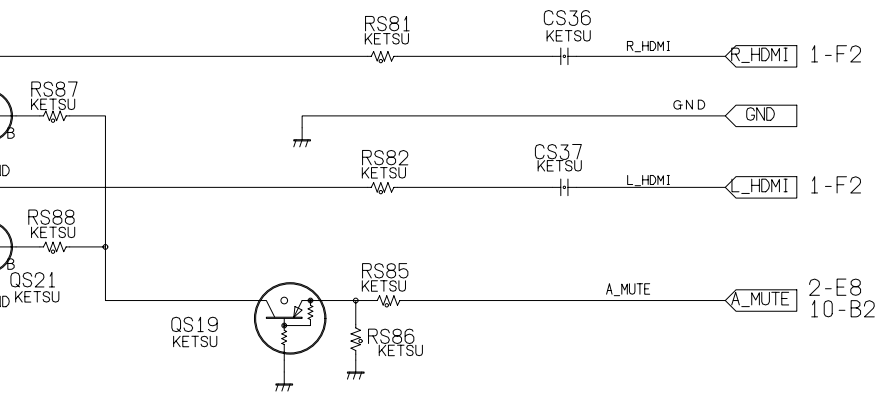
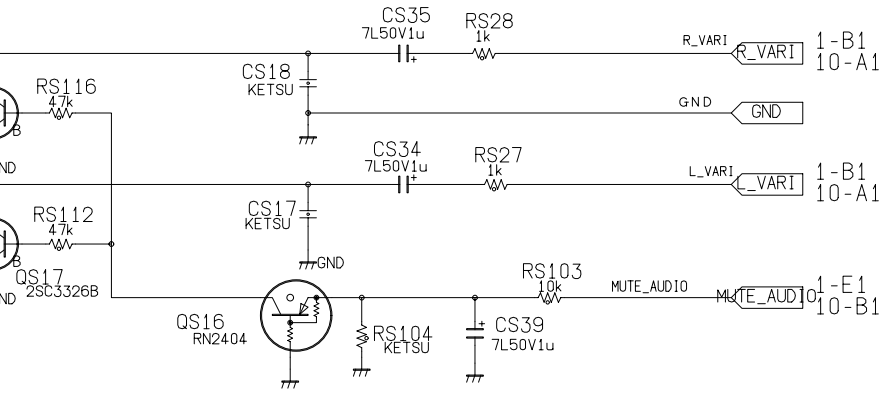

A

B

26HL83
SIGNAL - VARI-OUTPUT/HDMI-Mute
[SHEET-8]

1

2

1-A5
 1-D2
 1-E2
 2-A4
 4-A4
 6-A6
 7-D8
 10-A1

9V

1-D2
 1-D5
 2-A4
 6-A6
 7-E8

5V2

1-E4
 2-A8

V_AV

SCL1

SDA1

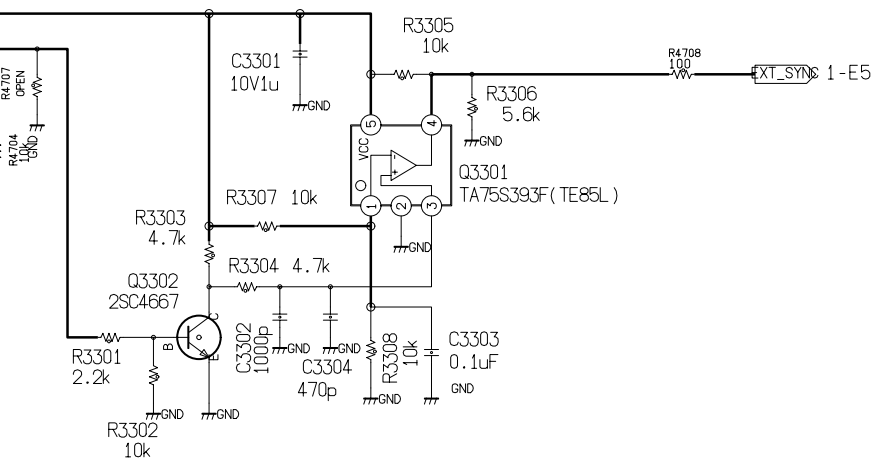
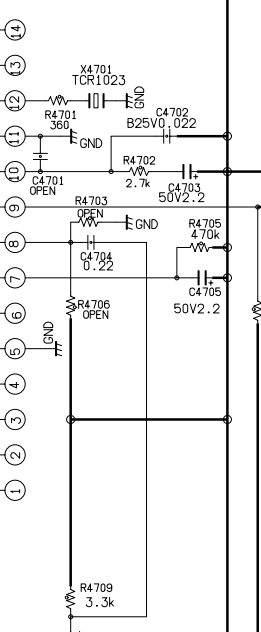
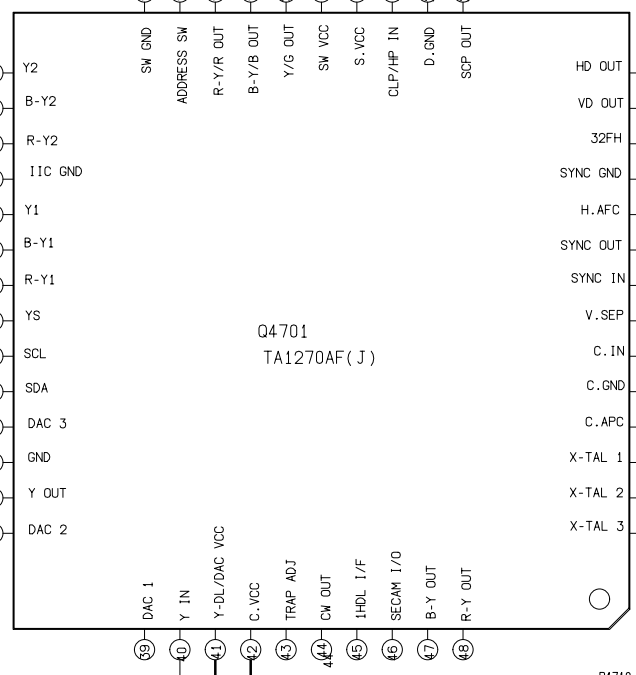
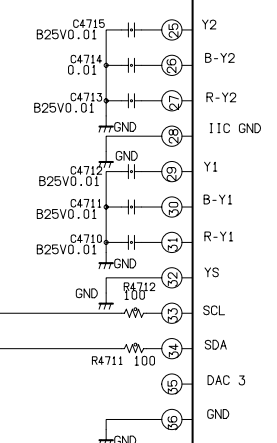
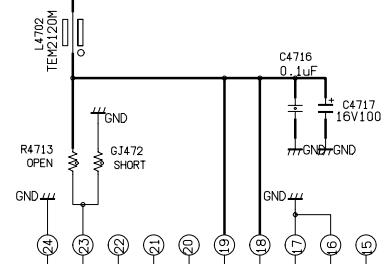

A

A

B

B

1

2

26HL83
 SIGNAL - SYNC OUT
 [SHEET-9]

A

B

- 1-A5
- 1-D2
- 1-E2
- 2-A4
- 4-A4
- 6-A6
- 7-D8
- 10-A1

9V

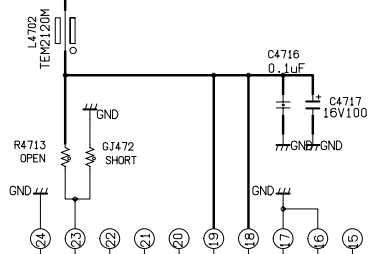

SCL1 SCL1
SDA1 SDA1

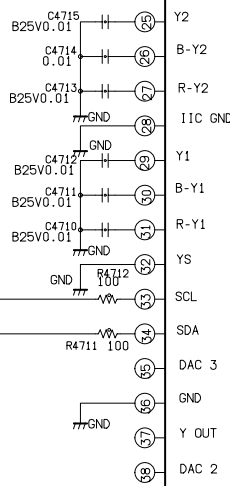

Q4701
TA1270AF (J)

- 1-D2
- 1-D5
- 2-A4
- 6-A6
- 7-E8

5V2

1-E4
2-A8
V_AV

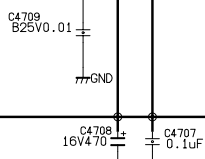

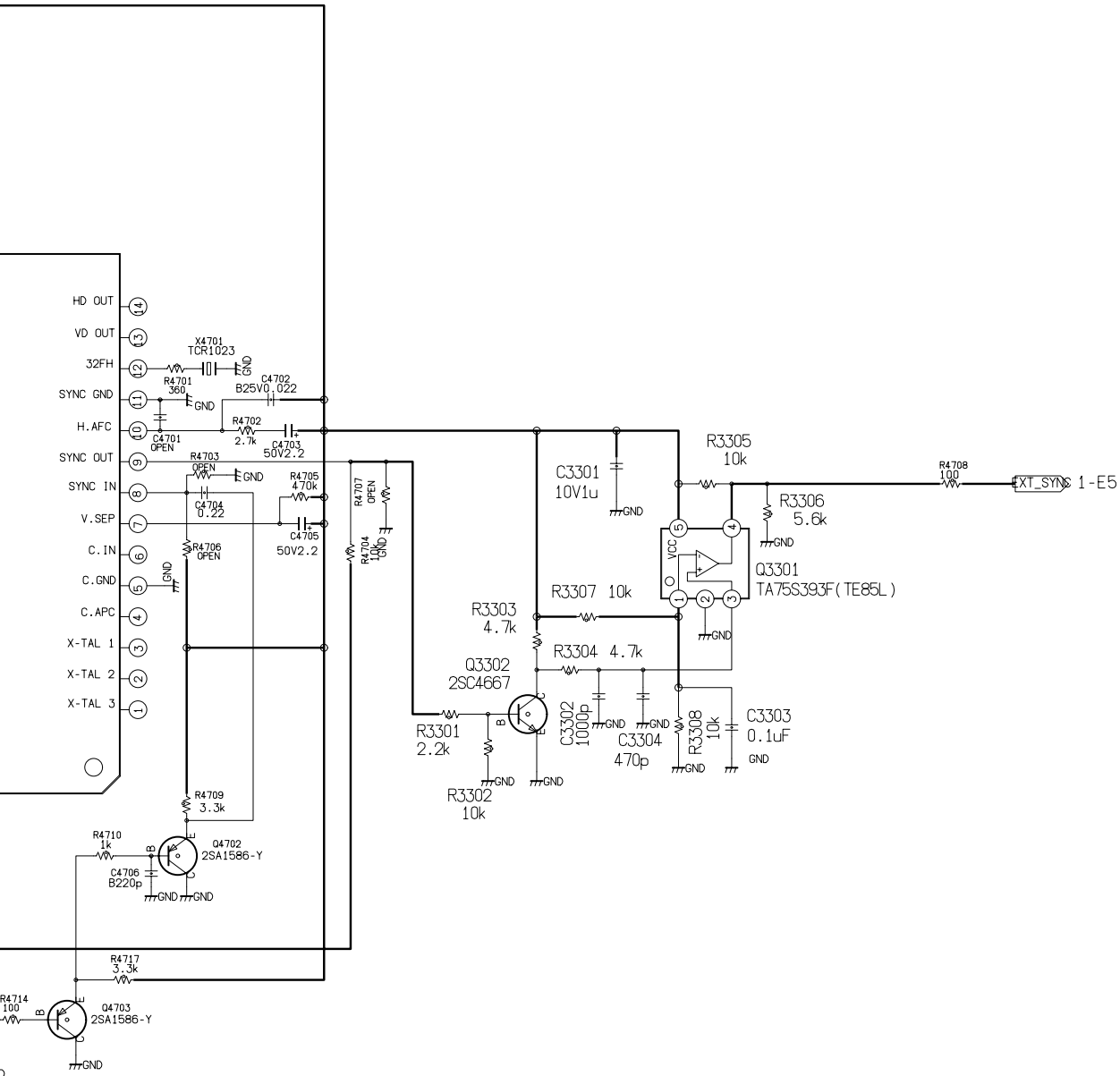

A

B

26HL83
 SIGNAL - SYNC OUT
 [SHEET-9]

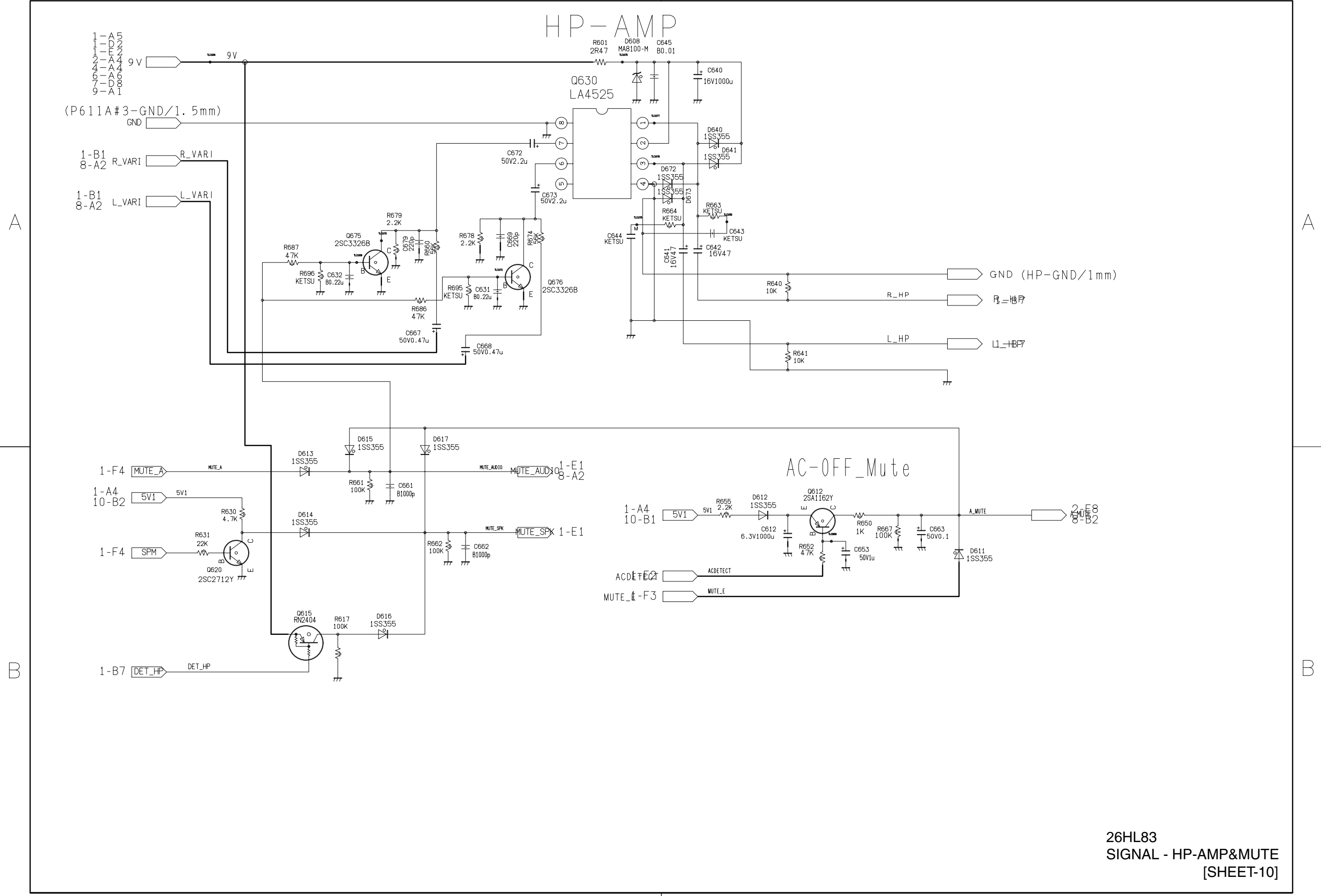

HP - AMP

A

B

1-A5
1-D2
1-E2
2-A4
4-A4
6-A6
7-D8
9-A1

9V

(P611A#3-GND/1.5mm)

GND

1-B1 R_VARI
8-A2 R_VARI

1-B1 L_VARI
8-A2 L_VARI

1-F4 MUTE_A
MUTE_A

1-A4 5V1
10-B2 5V1

1-F4 SPM
R631 22K
Q620 2SC2712Y

1-B7 DET_HP
DET_HP

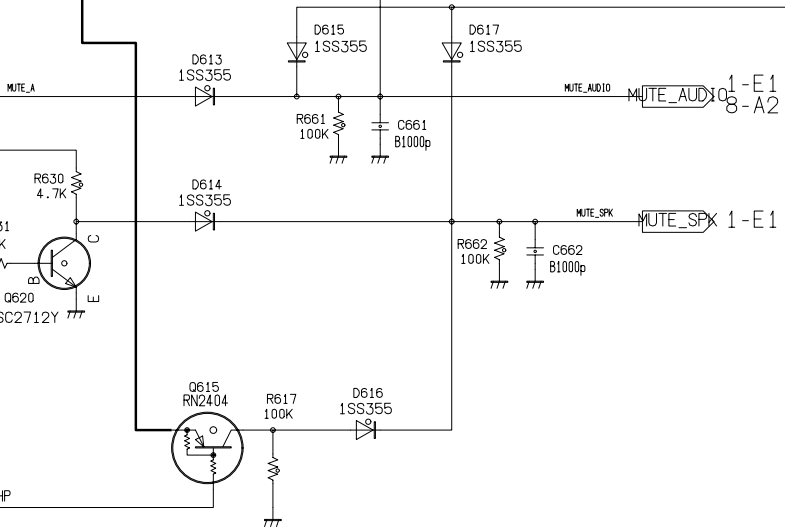
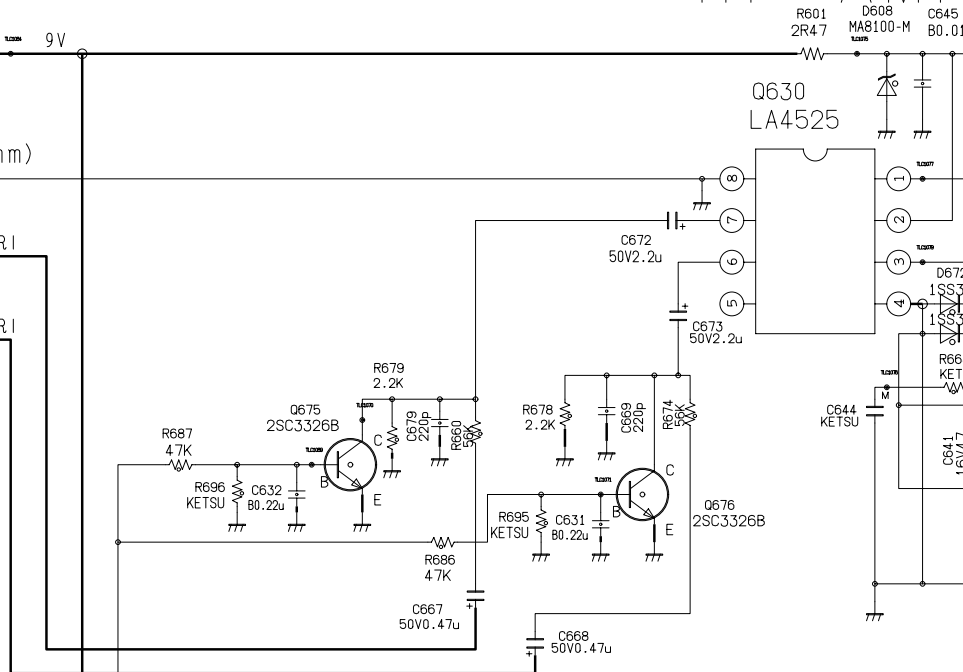

MP

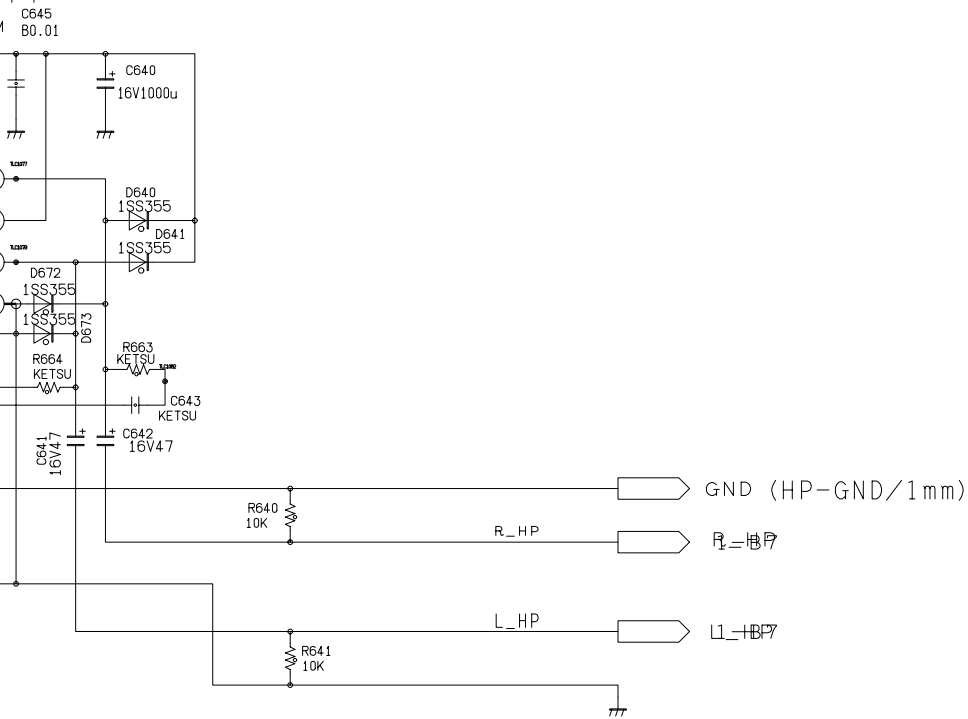

A

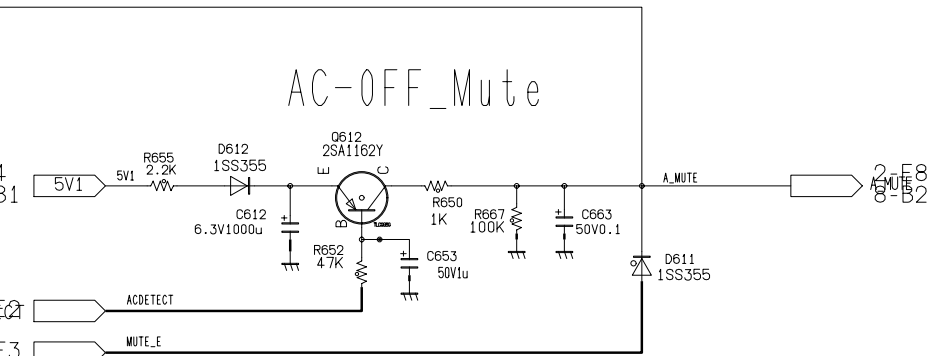

B

26HL83
 SIGNAL - HP-AMP&MUTE
 [SHEET-10]

A

B

C

D

E

F

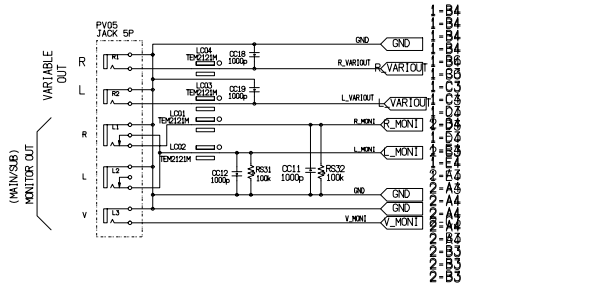
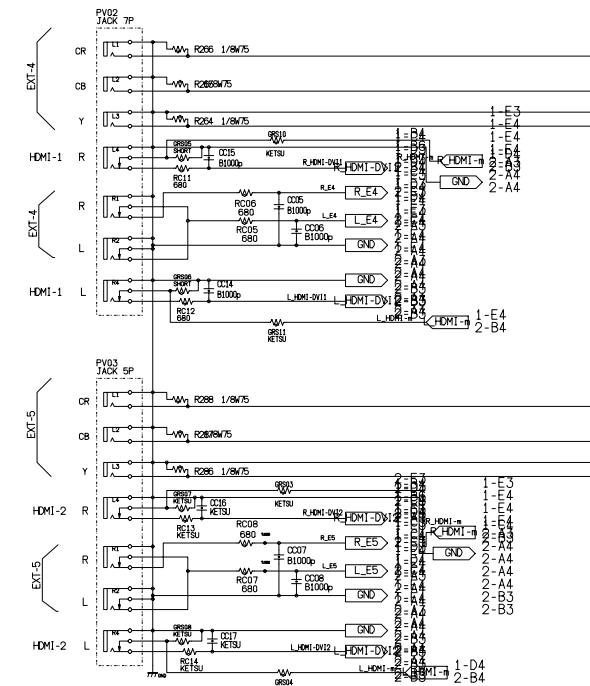
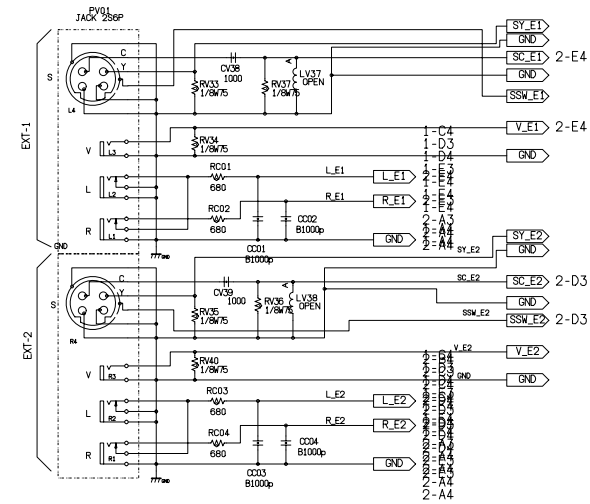

A

B

C

D

E

F

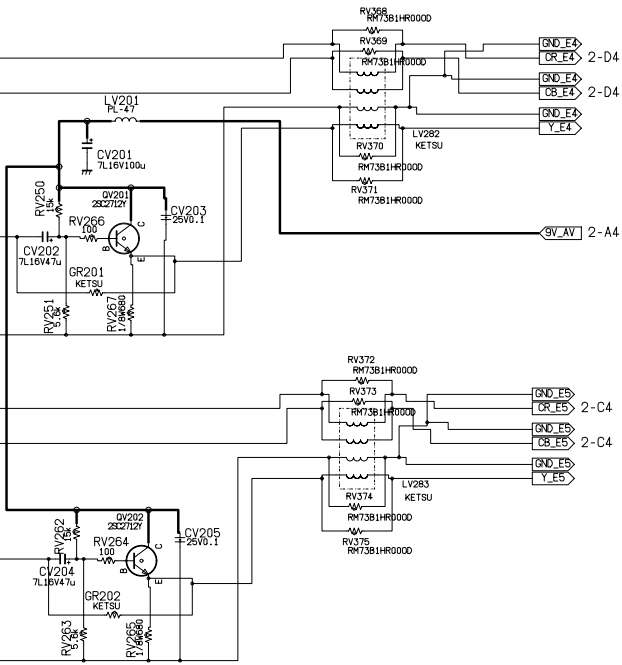
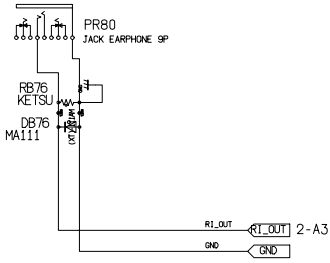

1

2

3

4

5

6

7

8

A

B

C

D

E

F

A

B

C

D

E

F

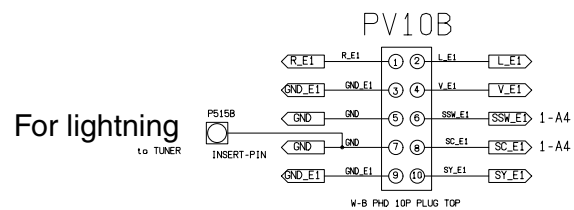
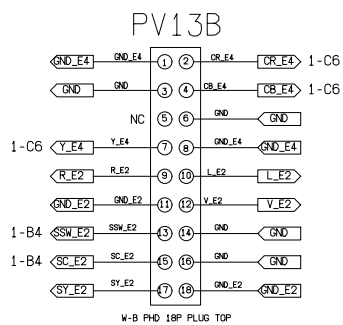
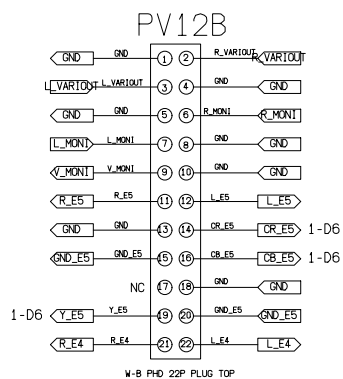
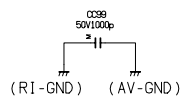
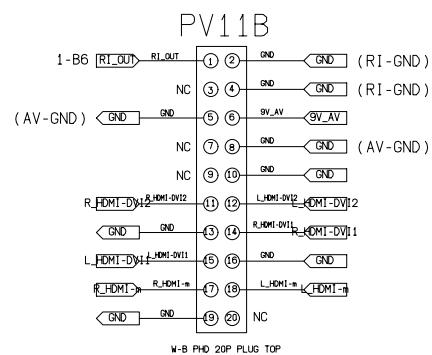

1

2

3

4

5

6

7

8

A

B

C

D

E

F

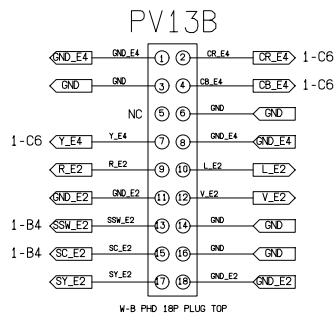
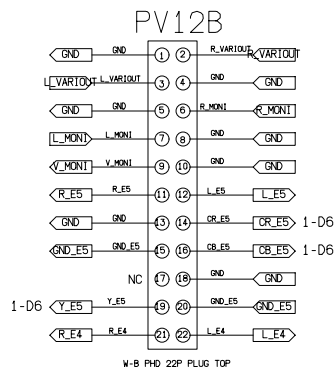
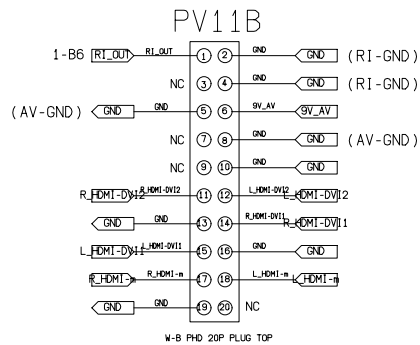

For lightning
to TUNER

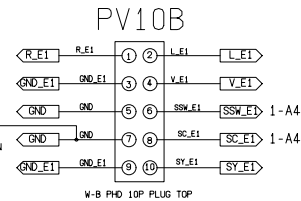

5

6

7

8

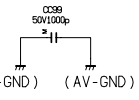

A

B

C

D

E

F

26HL83
BACK AV - BACK-AV3
[SHEET-2]

5

6

7

8

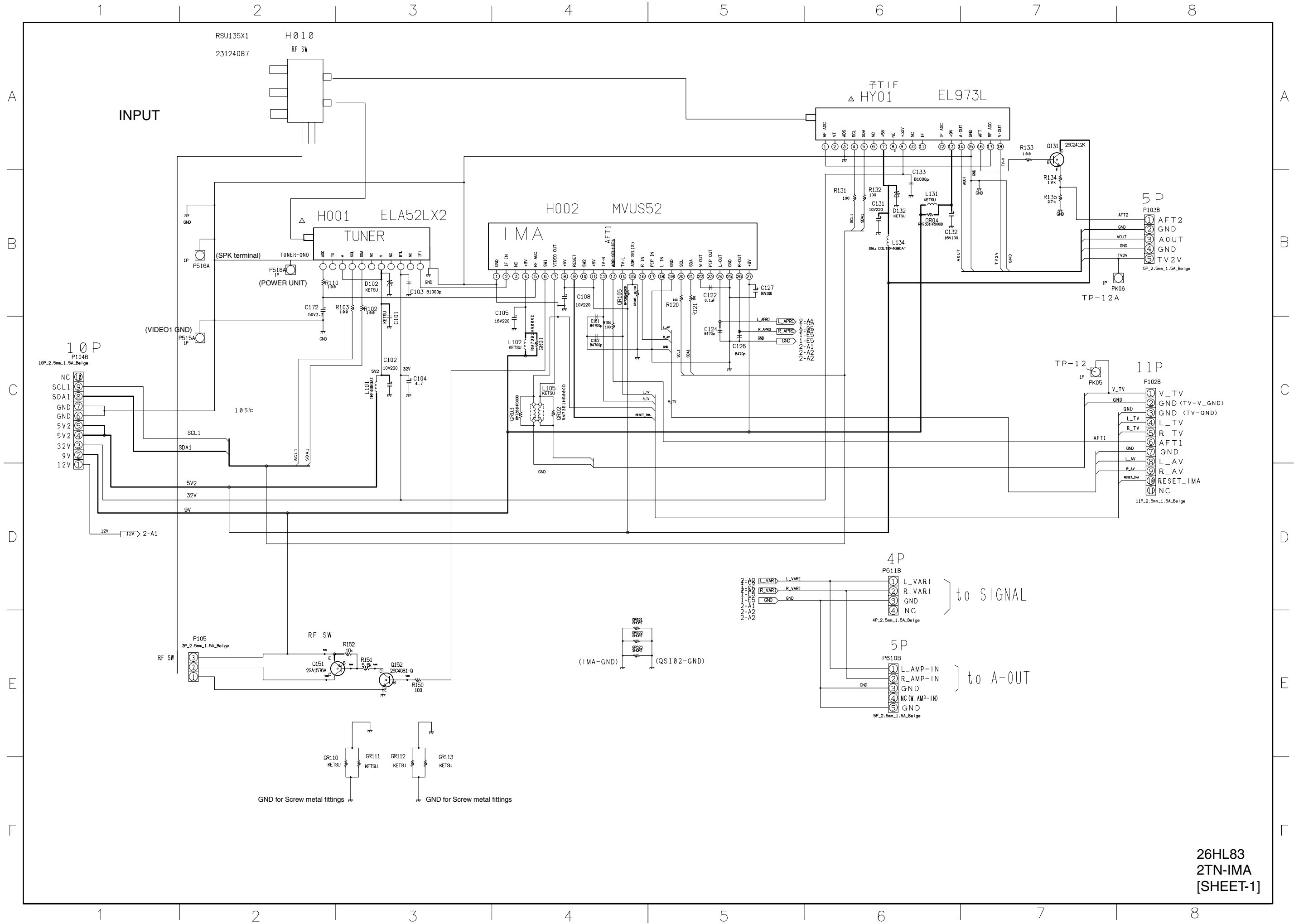

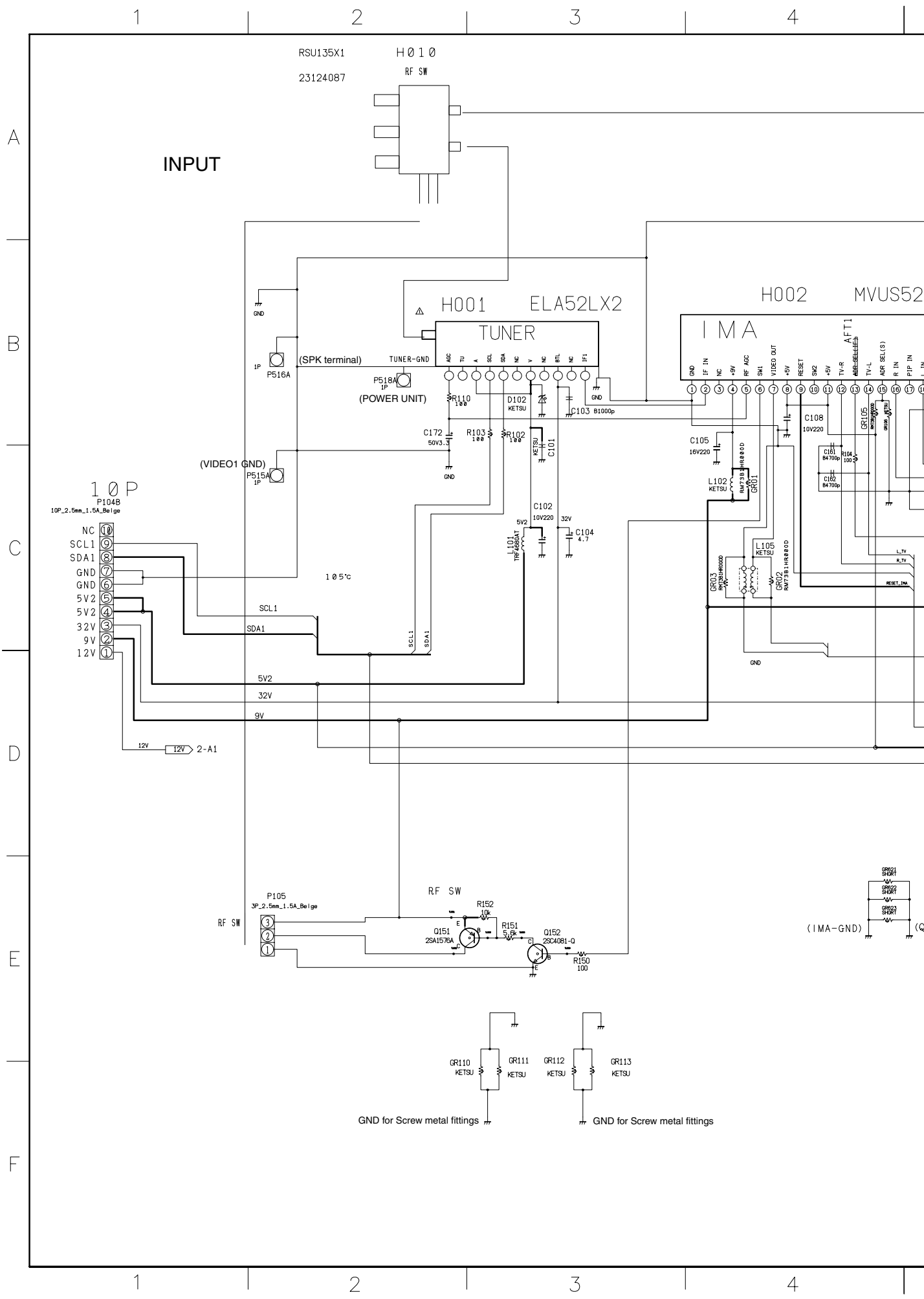

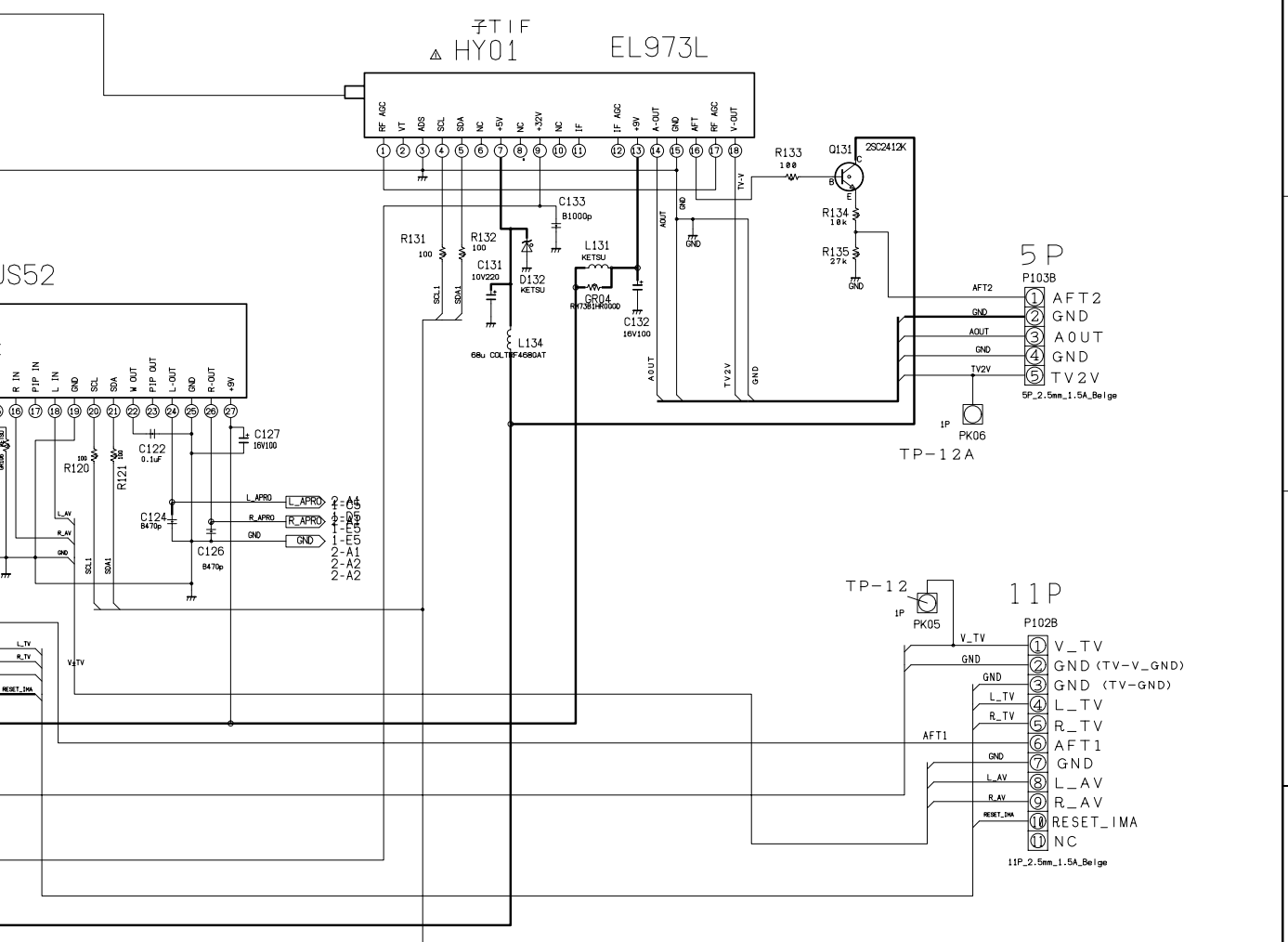

S52

L_TV, R_TV, RESET_IMA

RESET_IMA, (QS102-GND)

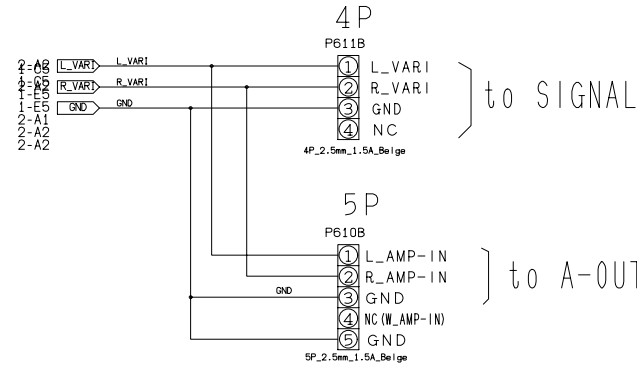

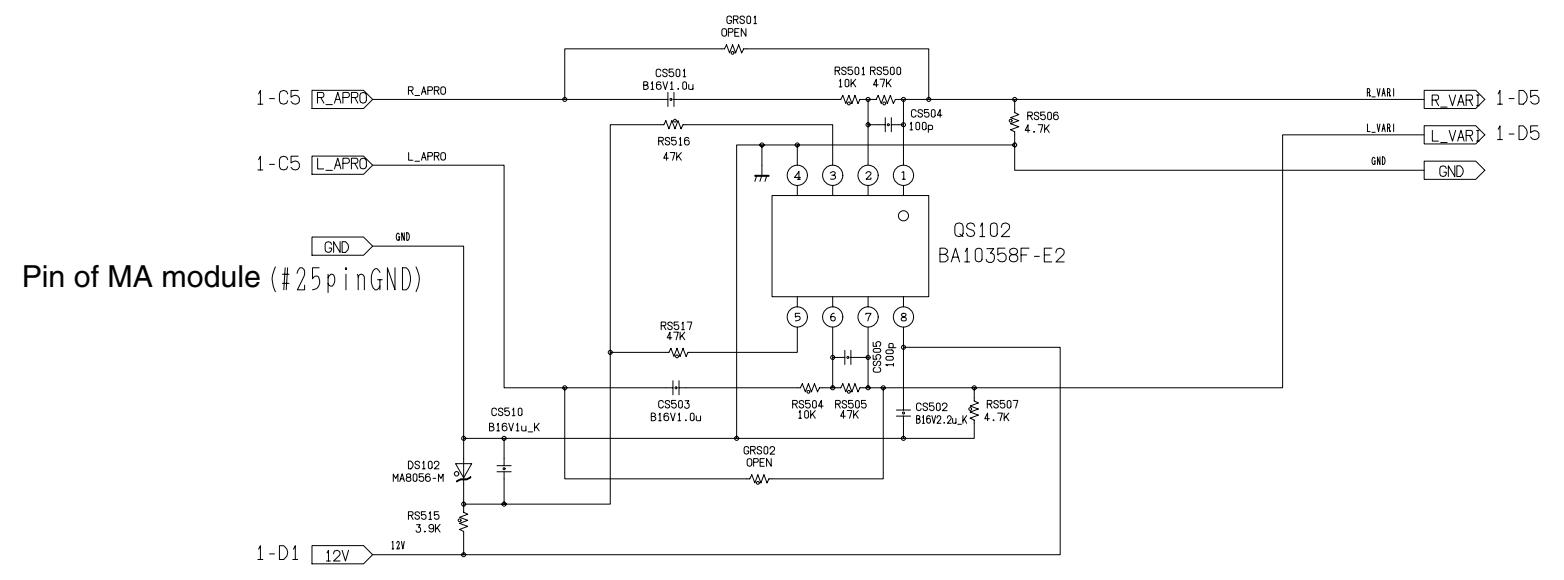

A

Pin of MA module (#25pinGND)

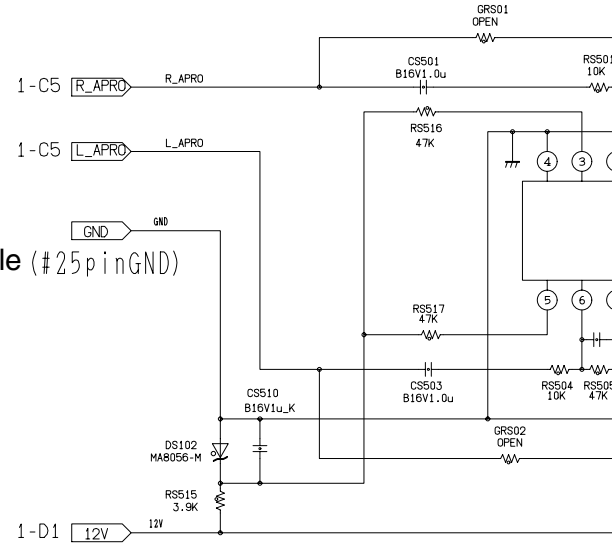

B

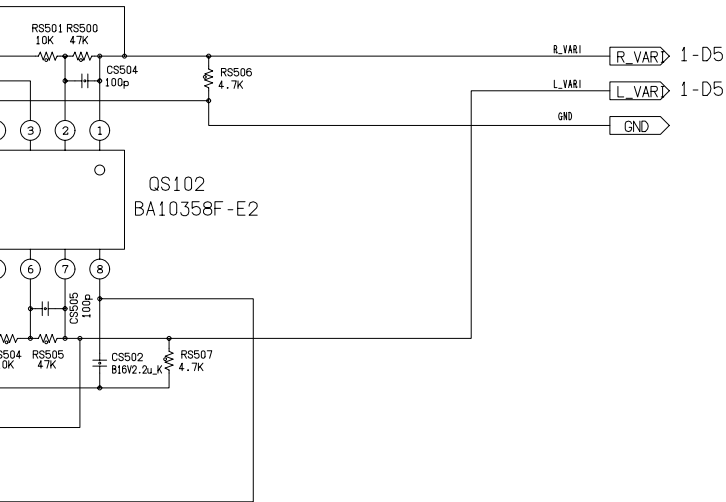

A

B

26HL83
AUDIO GAIN COMPENSATION
[SHEET-2]

A

A

U00 FRONT AV

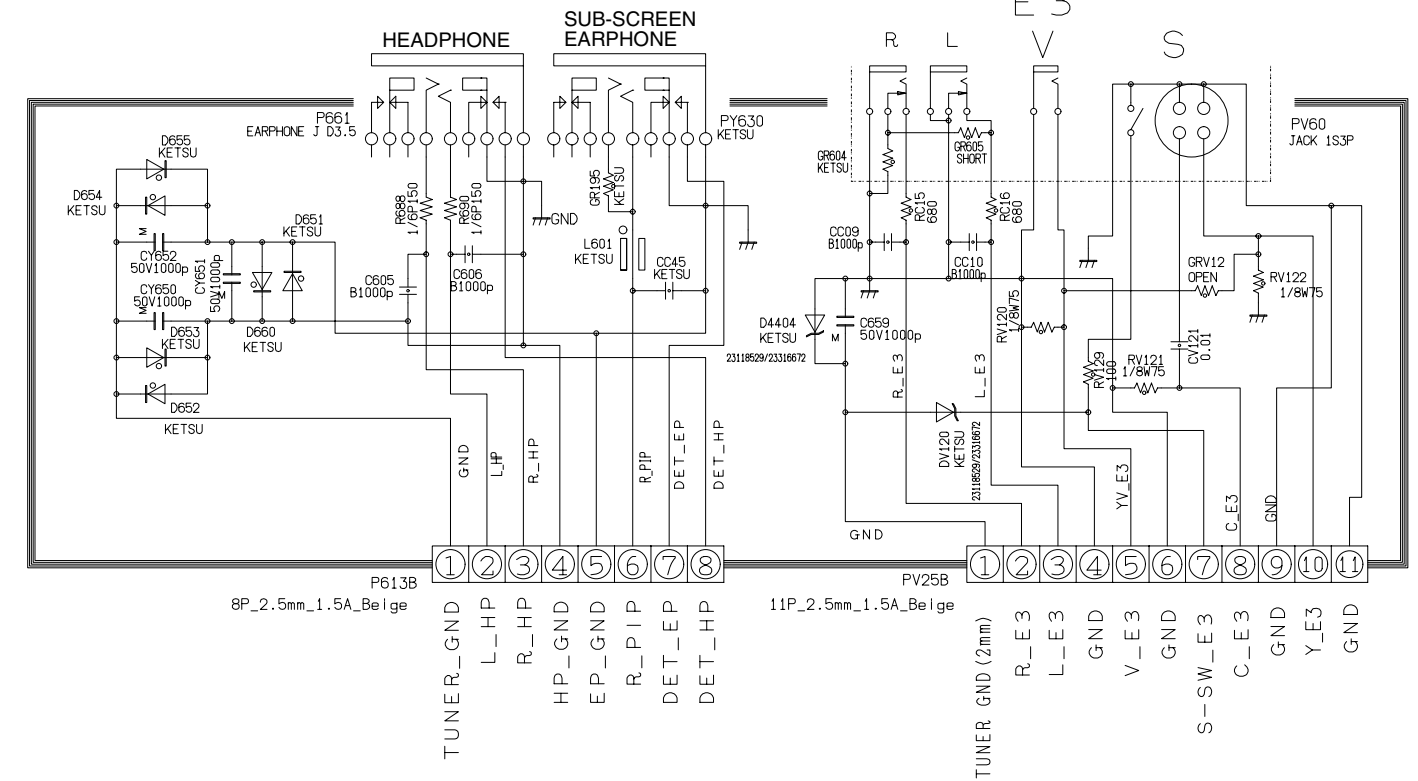

B

B

A

U00 FRONT AV

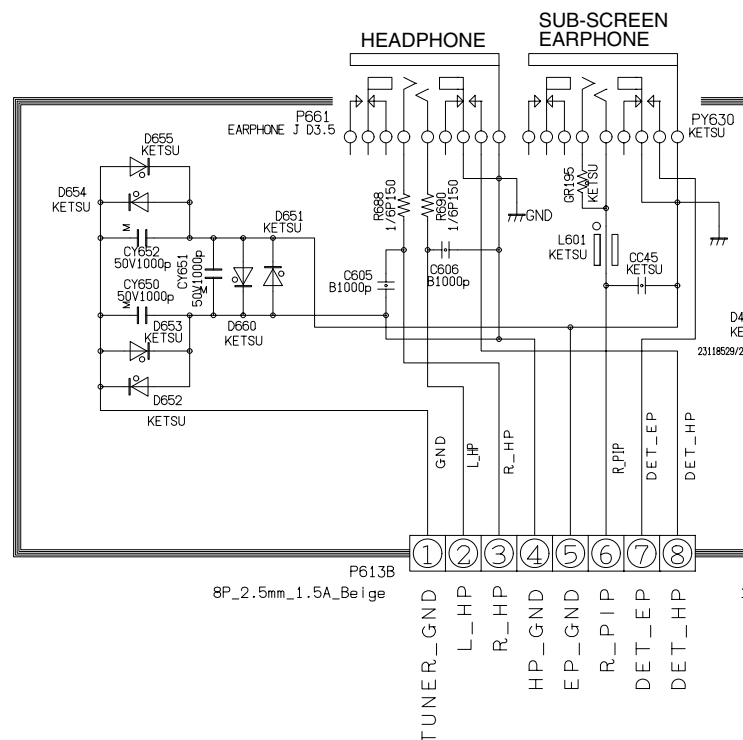

B

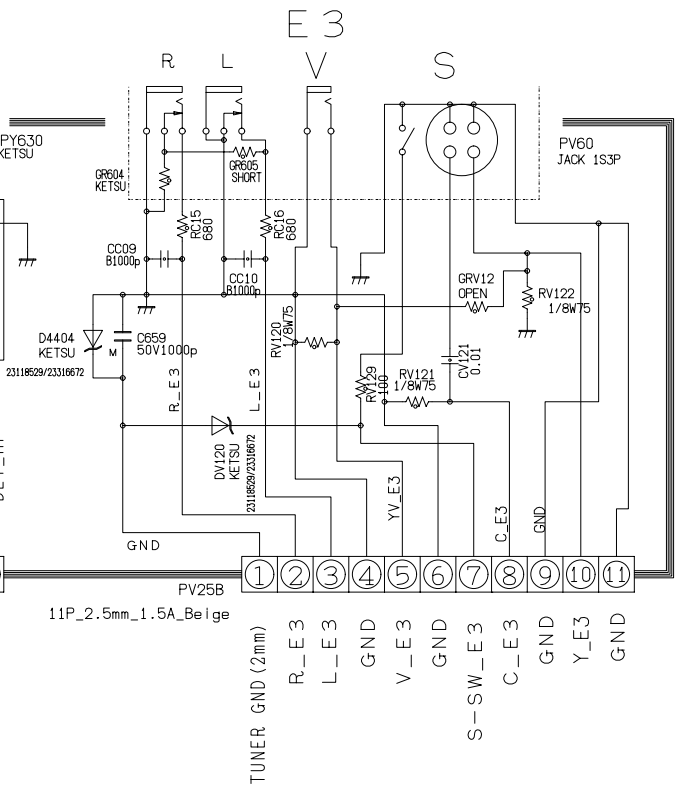

A

B

26HL83
FRONT AV

1

2

A

A

U00 KEY

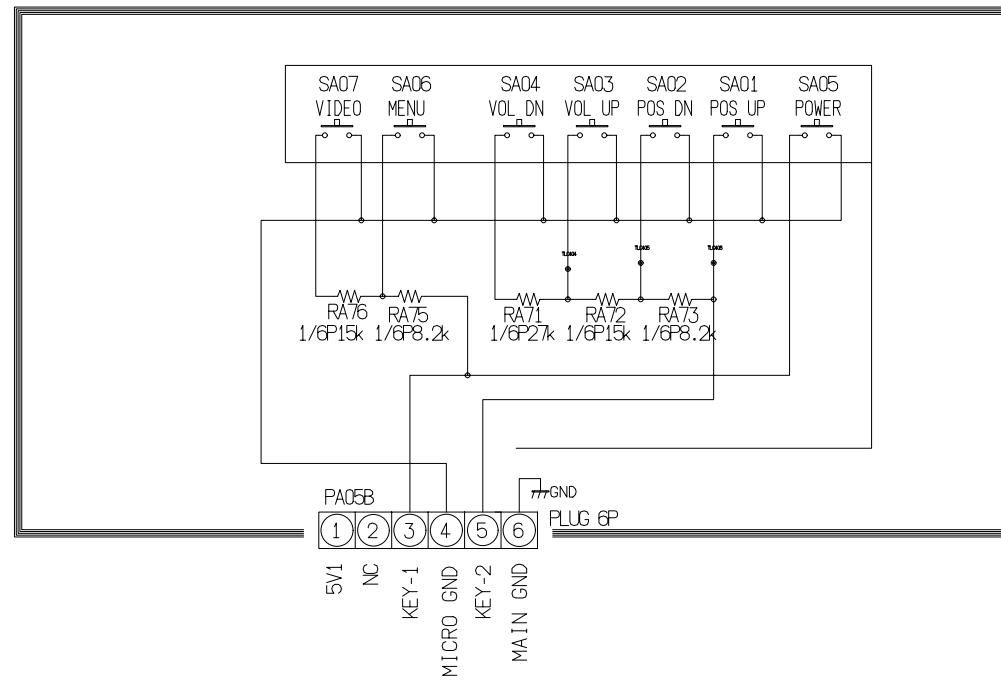

B

B

1

2

26HL83
KEY

A

U00 KEY

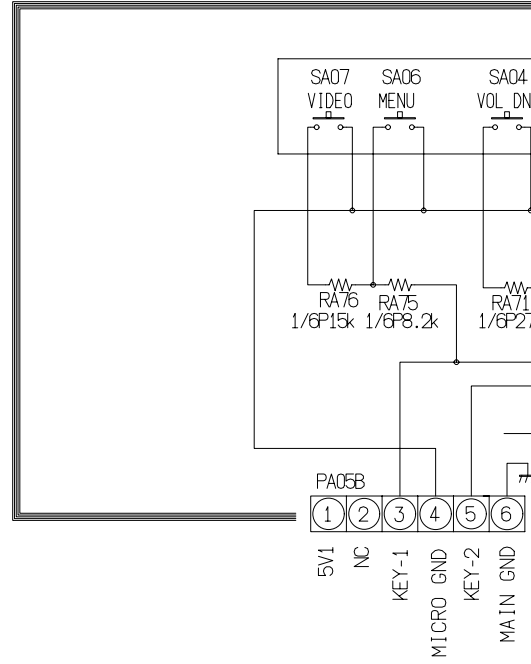

B

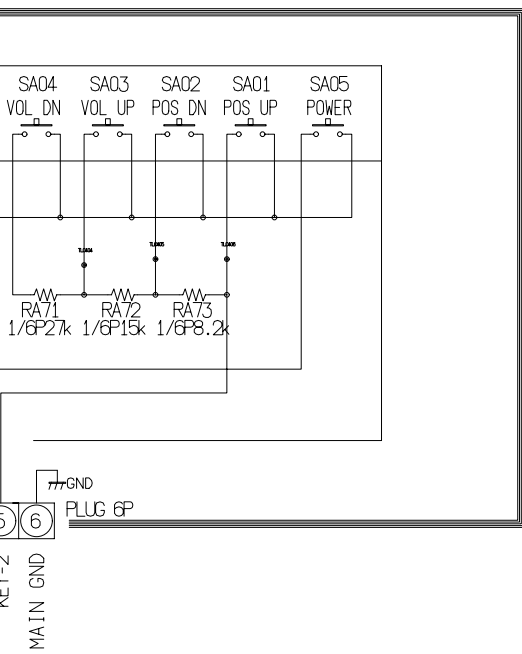

A

B

26HL83
KEY

1

2

A

A

U0 PC

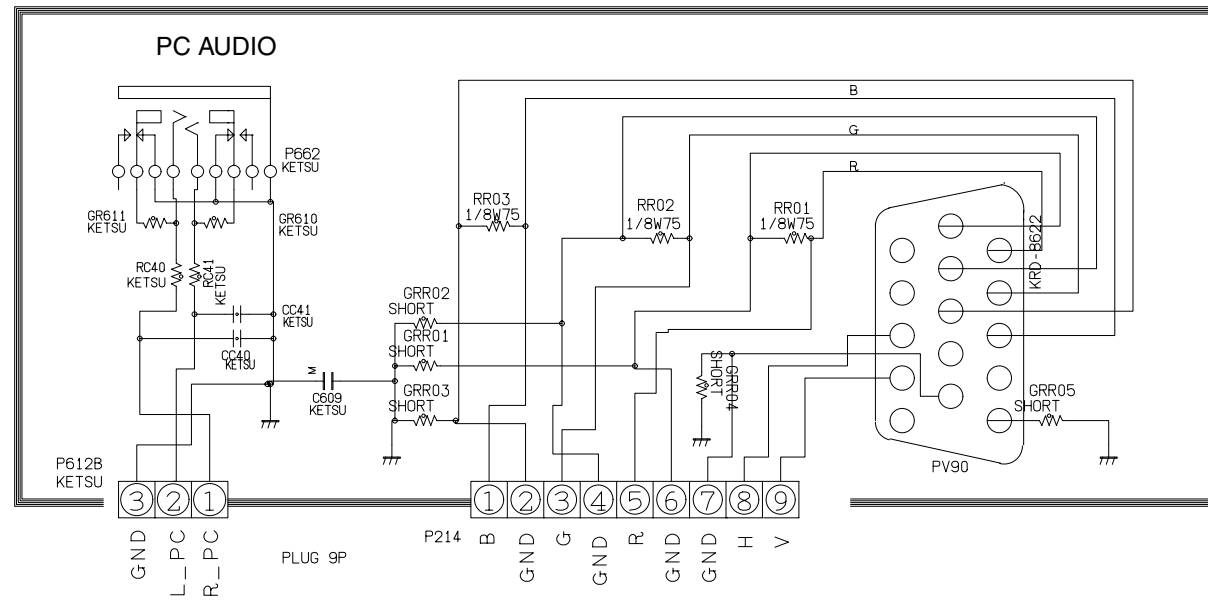

B

B

1

2

26HL83
PC INPUT

A

U0 PC

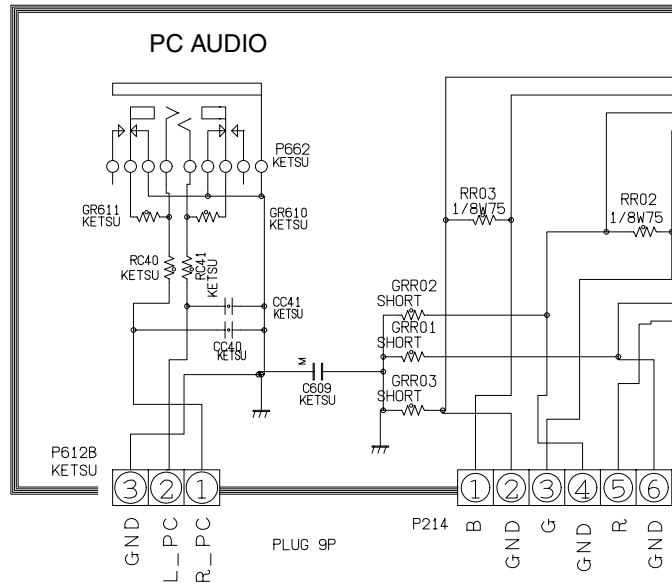

B

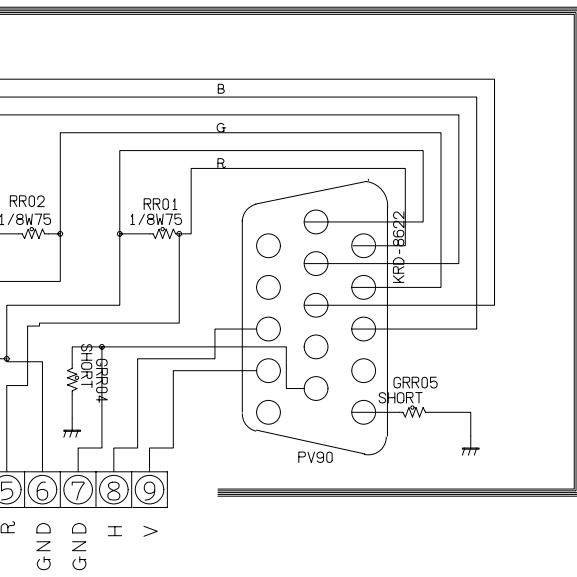

A

B

26HL83
PC INPUT

1

2

A

A

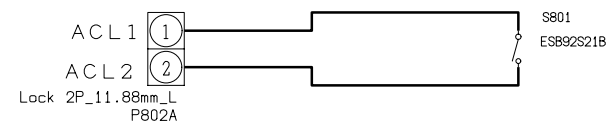

B

B

26HL83
POWER SW

1

2

1

A

B

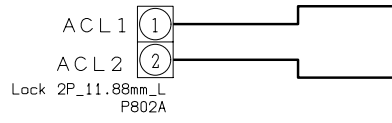

1

2

A

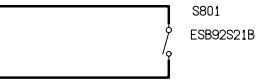

B

26HL83
POWER SW

2

1

2

A

A

G-HYPER

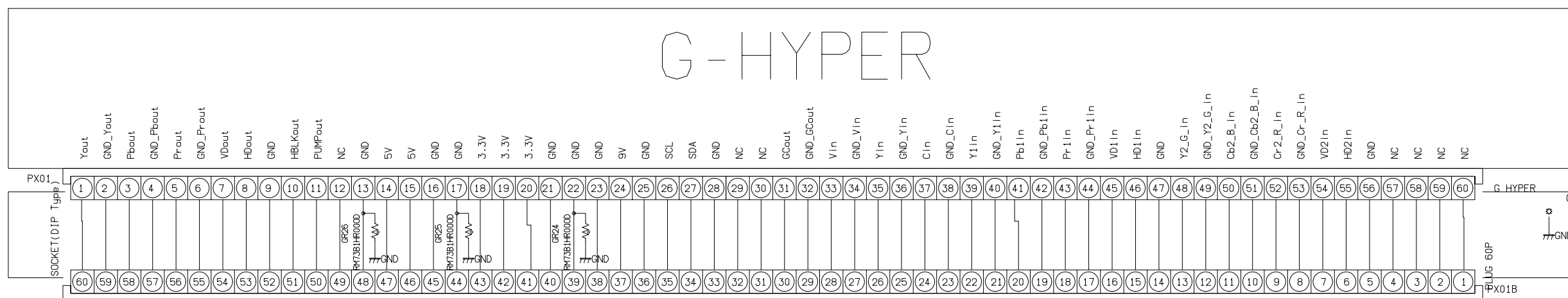

B

B

26HL83
G-HYPER

1

2

A

B

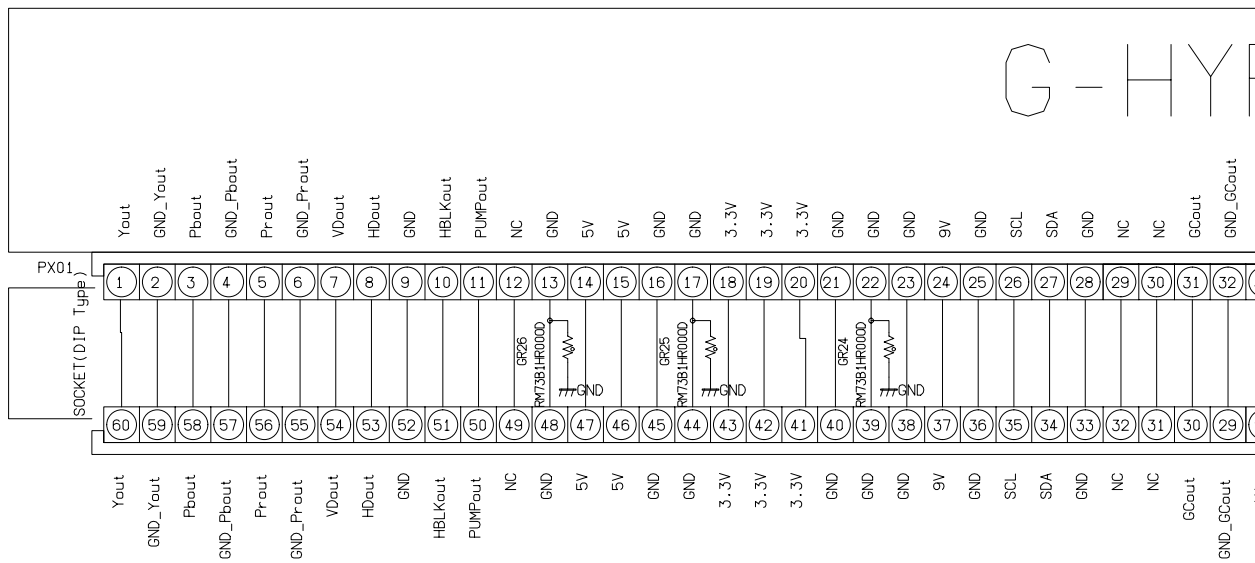

G-HYPER

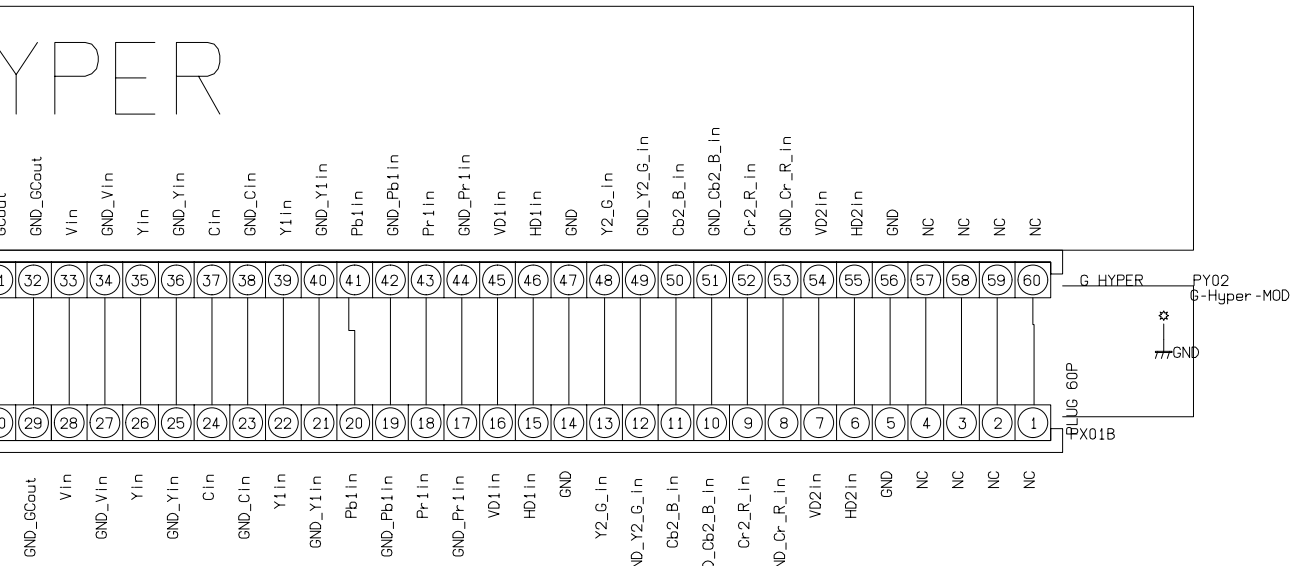

A

B

26HL83
G-HYPER

A

A

TUNER

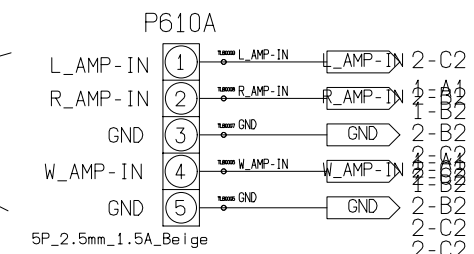

SIGNAL

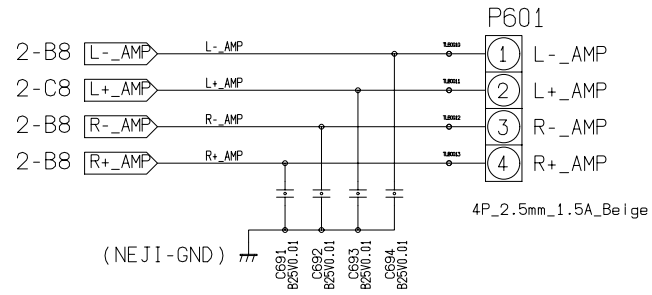
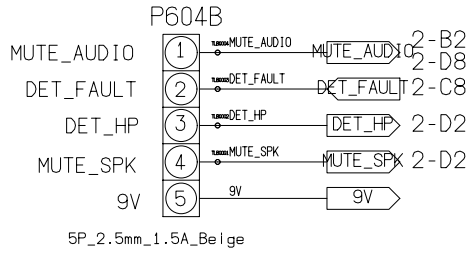

SPK_R/L
(all:2mm)

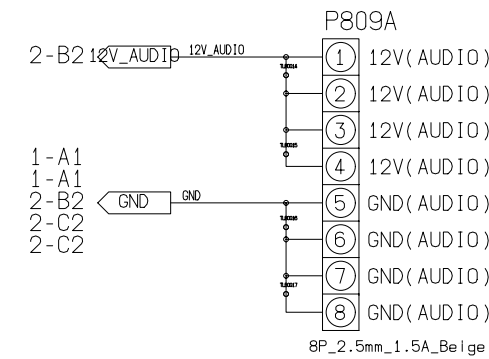

POWER

B

B

A

B

TUNER

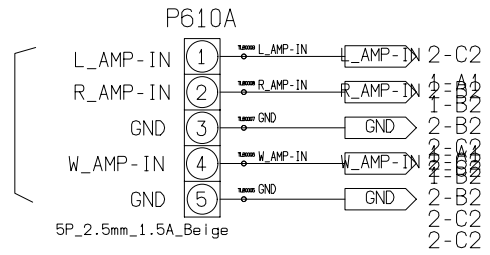

2-B8
2-C8
2-B8
2-B8

SIGNAL

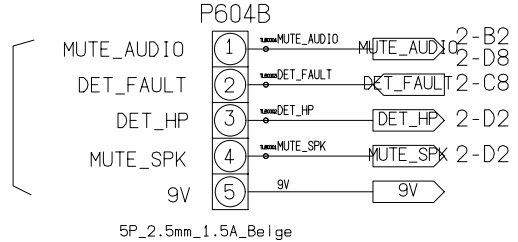

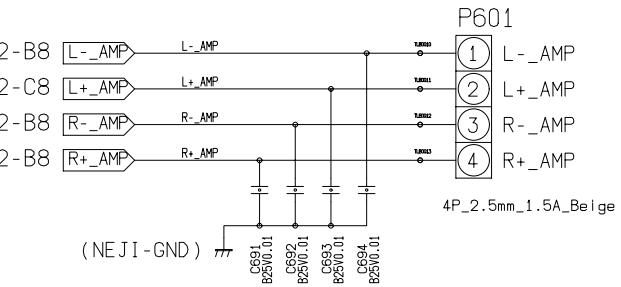

SPK_R/L
(all:2mm)

A

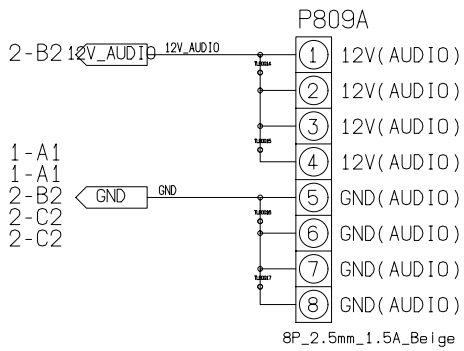

POWER

B

1

2

3

4

5

6

7

8

A

B

C

D

E

F

A

B

C

D

E

F

The surface patterns under Q610 and Q6100 should be GND, and make many more through-holes between surface GNDs as much as possible.

Corresponded to shielding (should be enclosed with GND)

AUDIO OUTPUT(R/L)

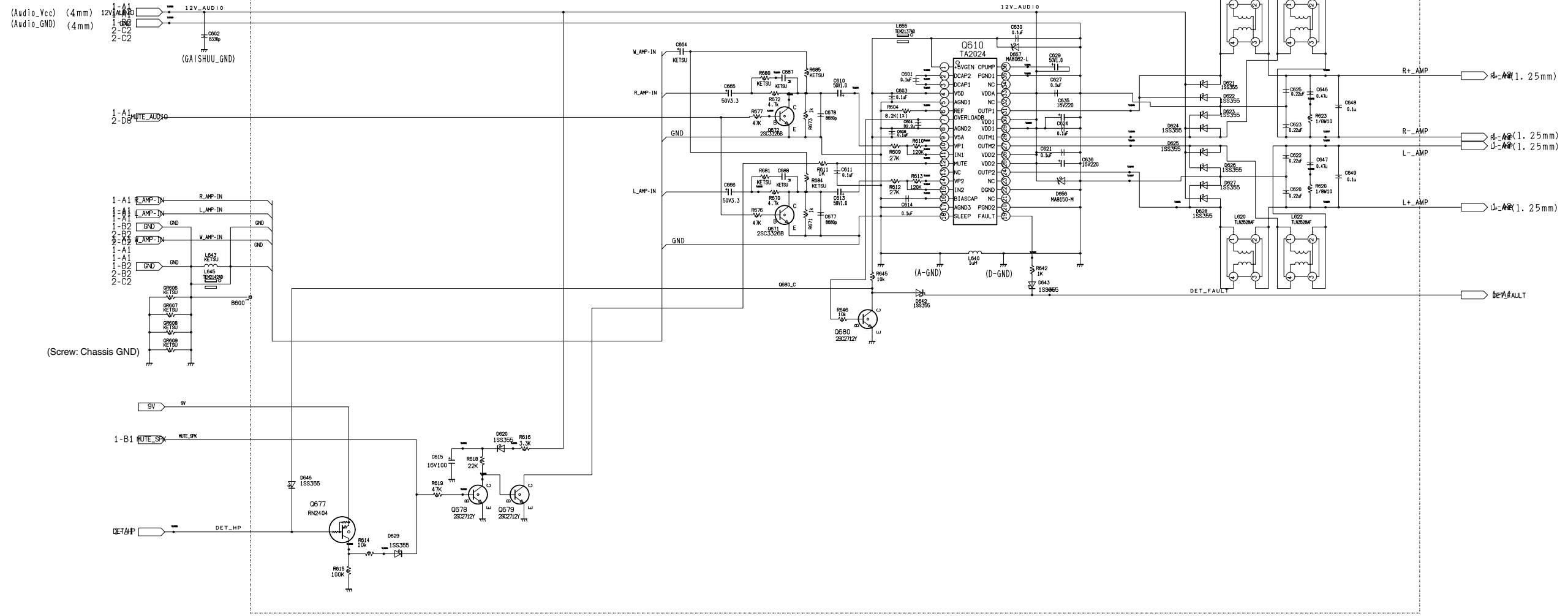

1

2

3

4

A

The surface patterns under Q610 and Q6100 should be GND through-holes between surface GNDs as much as possible.

Corresponded to shielding (should be enclosed with GND)

B

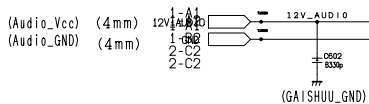

C

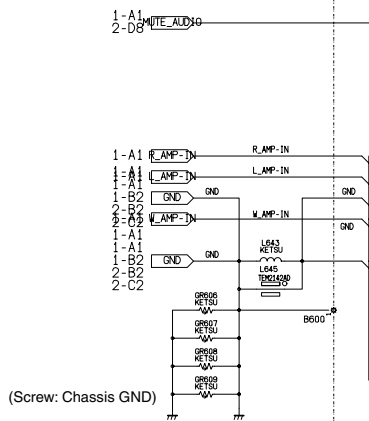

D

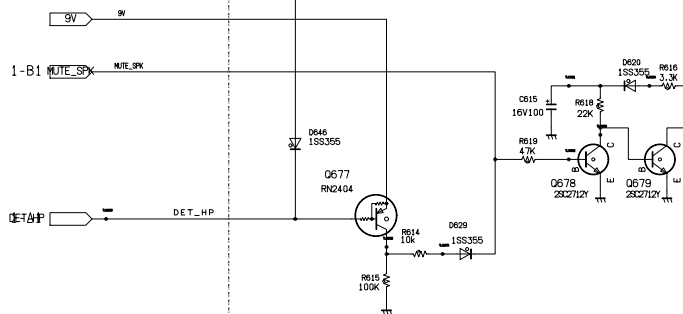

E

F

1

2

3

4

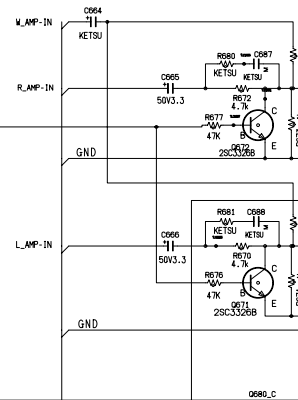

Q680_C

the GND, and make many more
sible.

AUDIO OUTPUT(R/L)

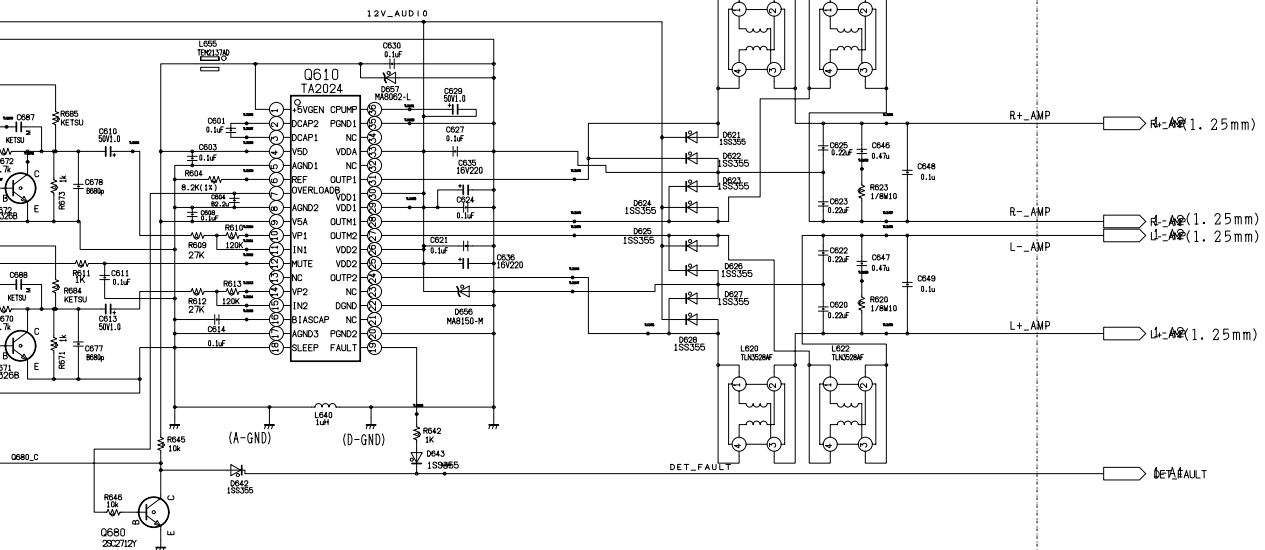

A

B

C

D

E

F

26HL83
A-OUT - (2/2)
[SHEET-2/2]

A

A

B

B

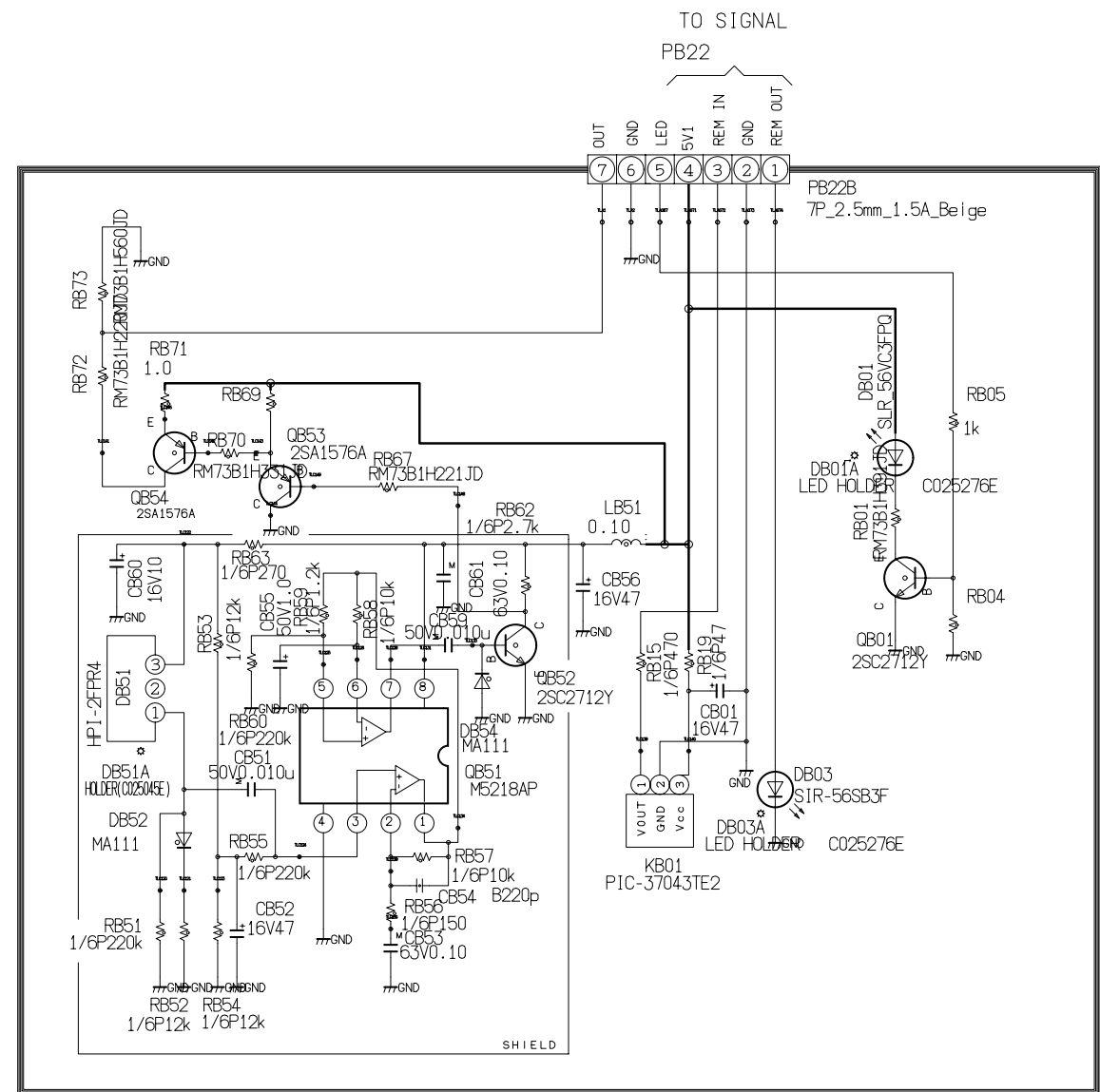

IR-PASS/RMT/LED

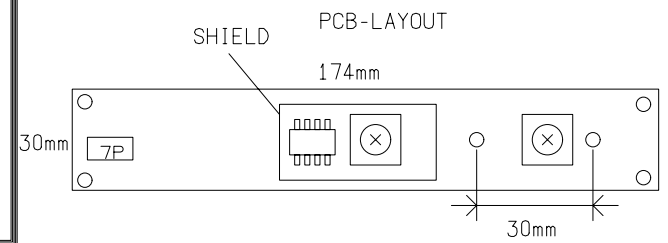

A

B

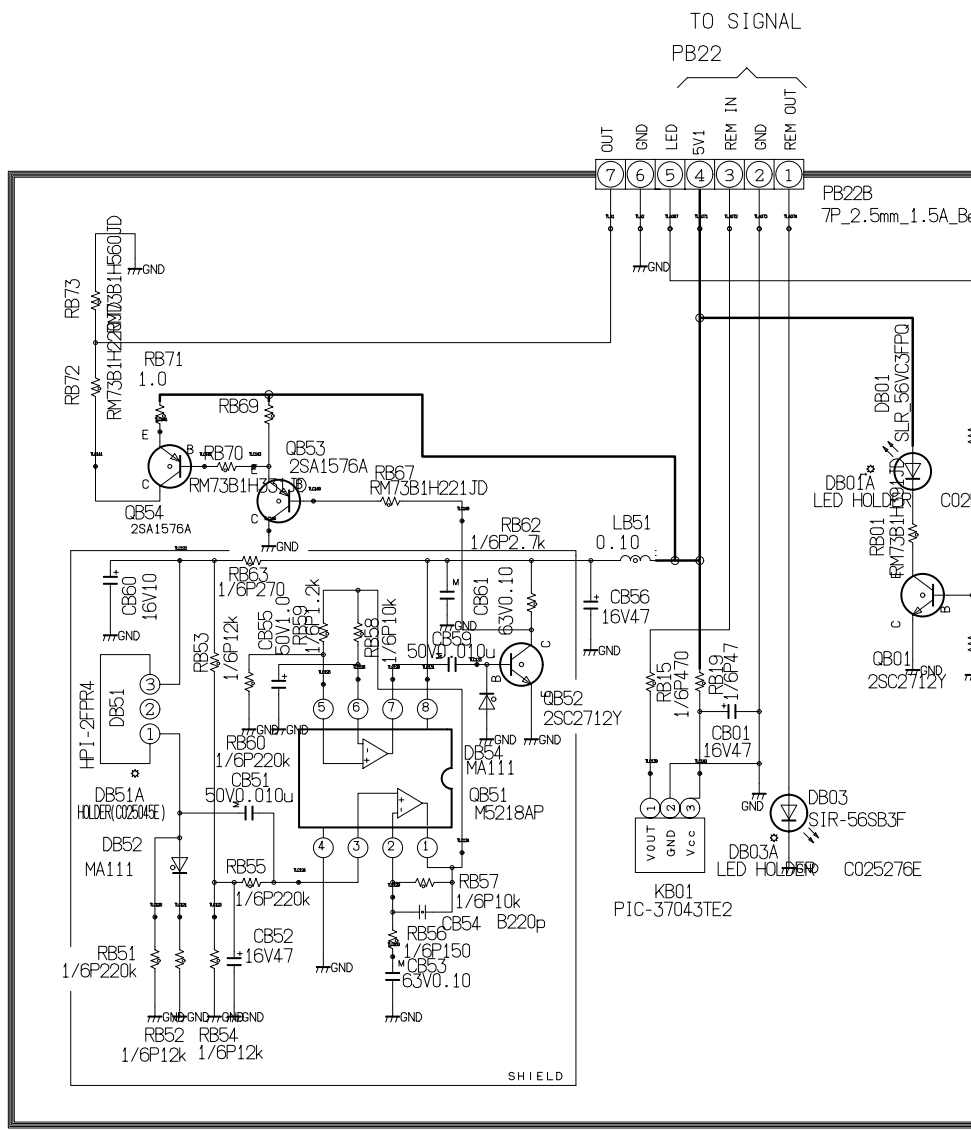

IR-PASS/RMT/LED

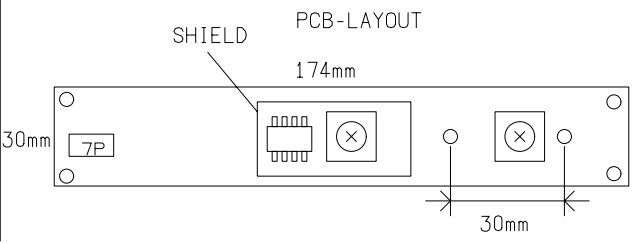
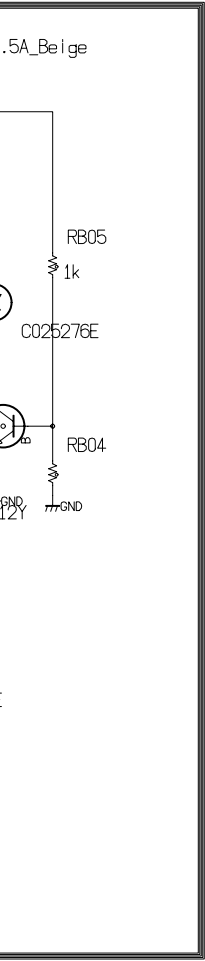

A

B

26HL83
IR-PASSTHROUGH

WIRING CONNECTION DIAGRAM

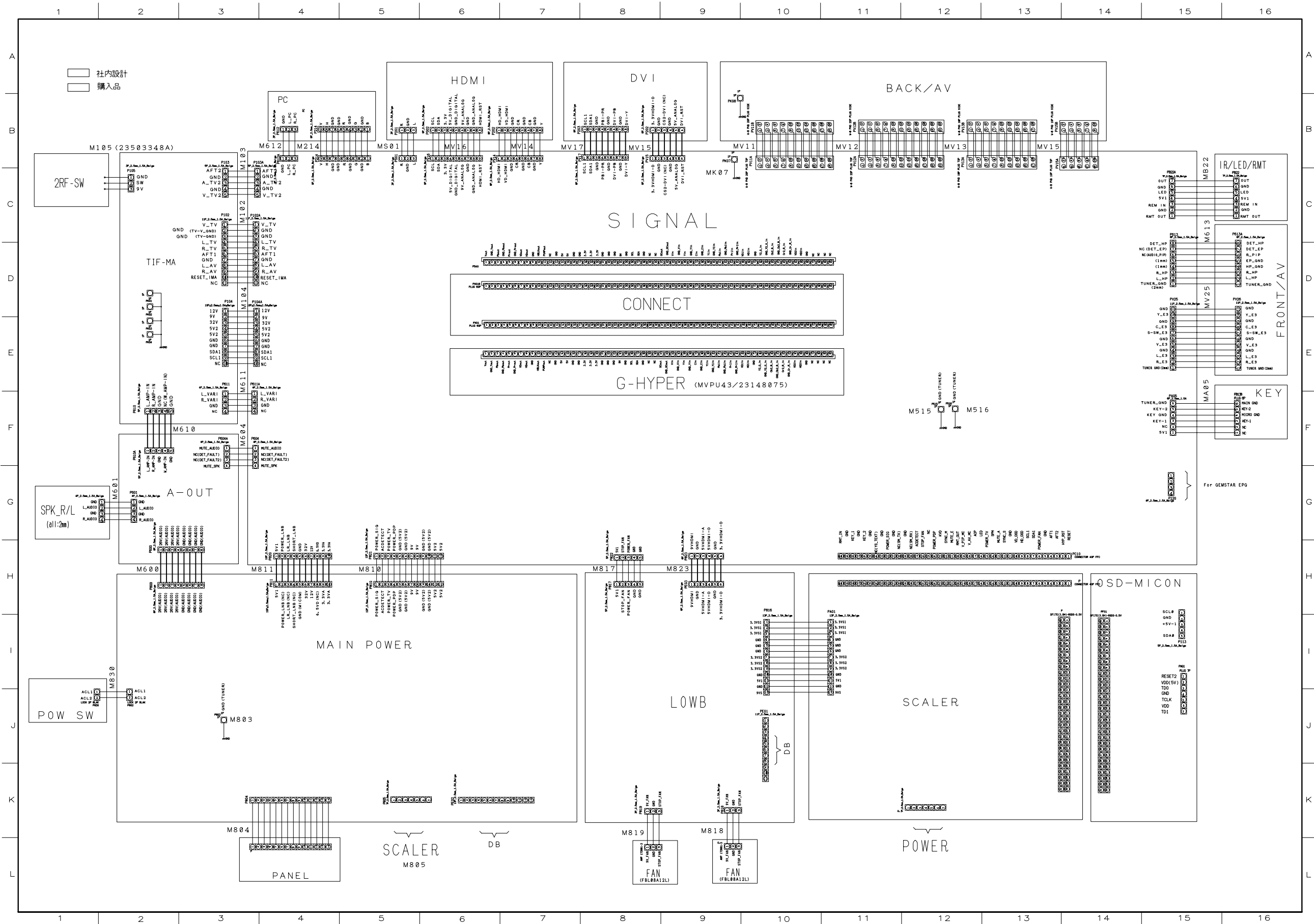

1

2

3

A

B

C

D

E

F

社内設計
 購入品

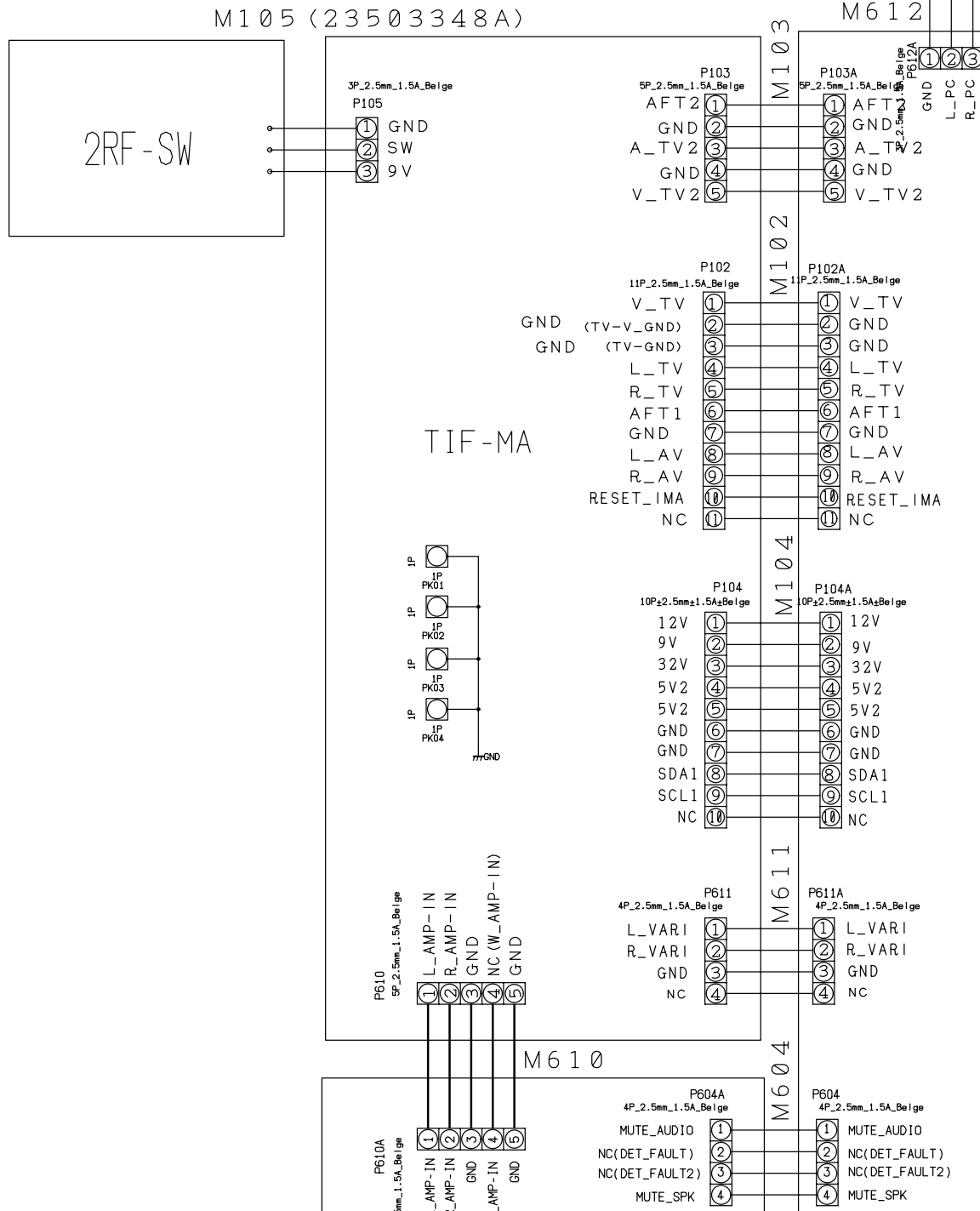

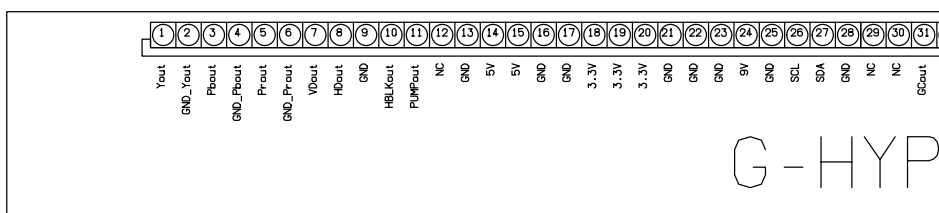
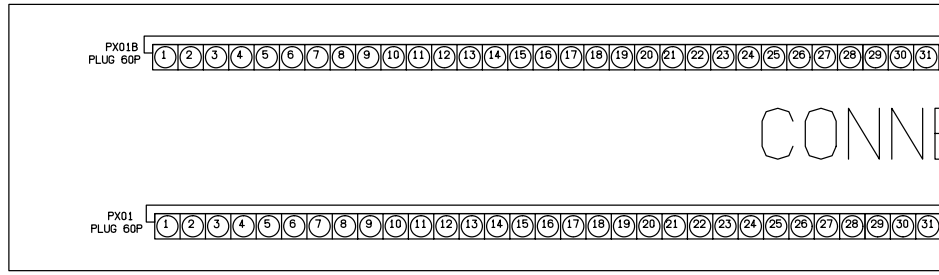
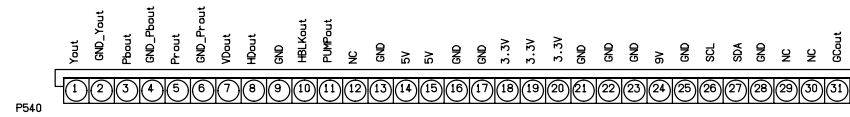
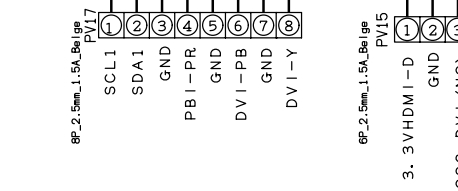
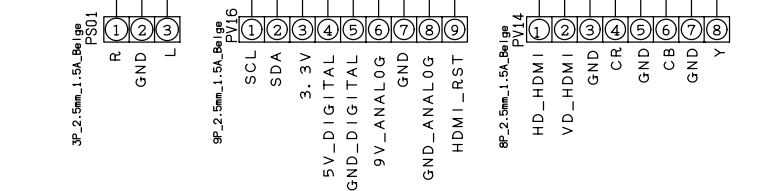
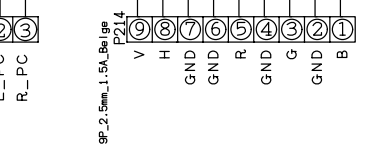
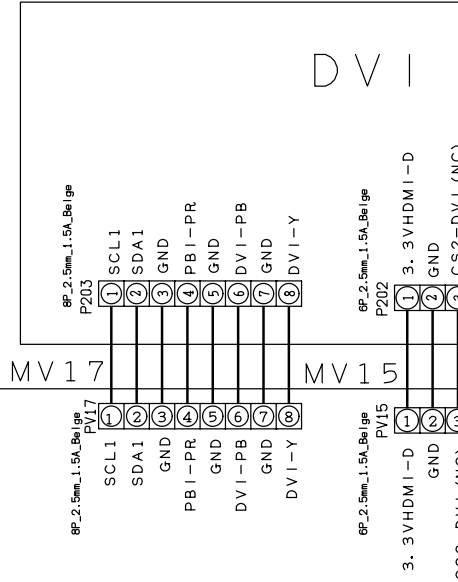
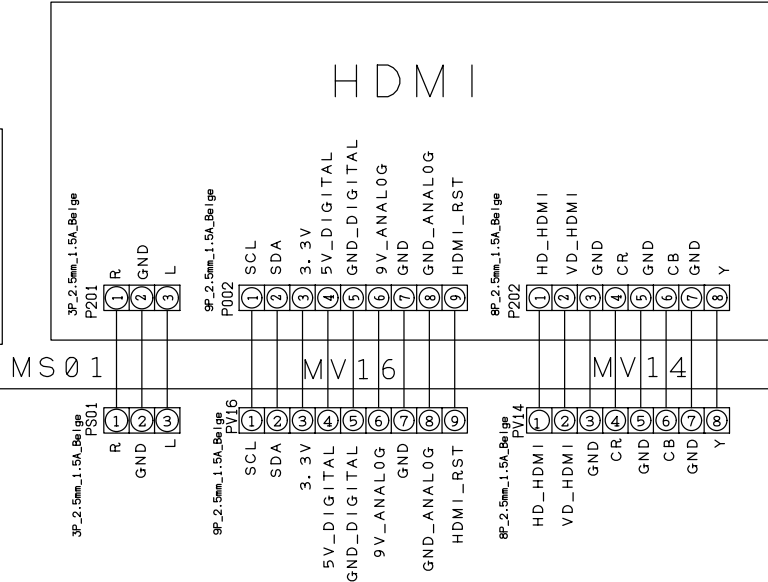
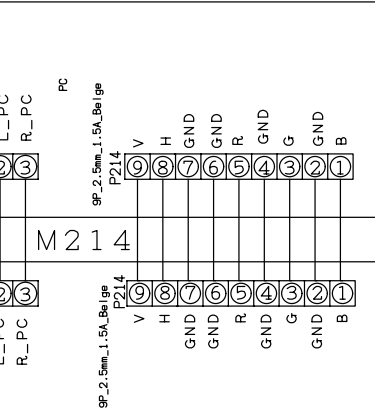

S I G

CONN

G-HYP

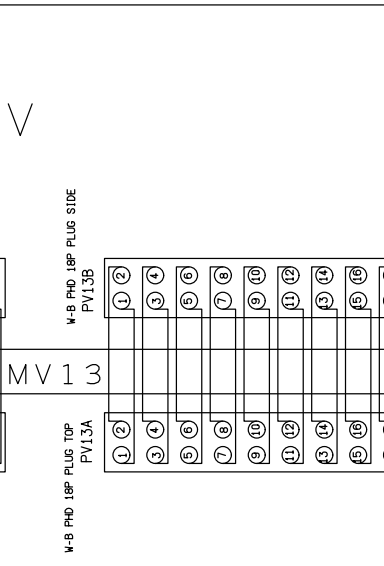
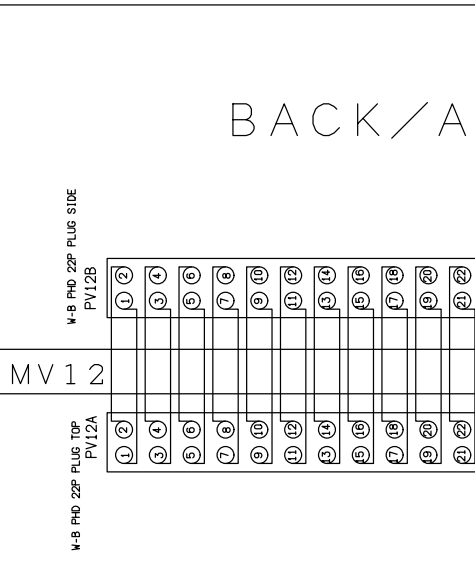
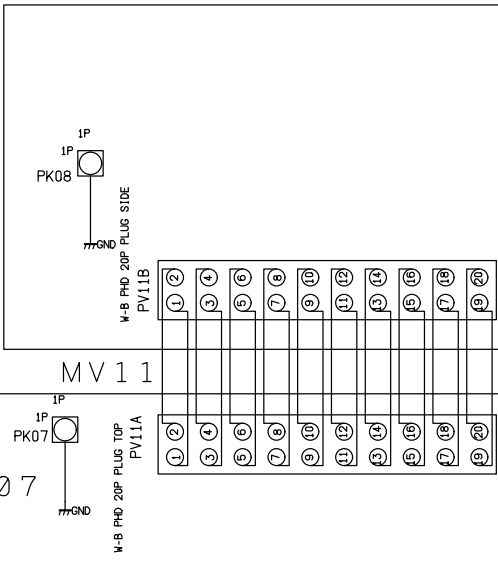
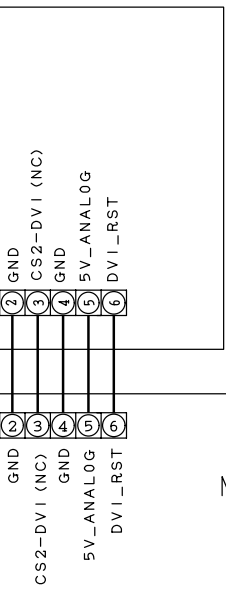

BACK/AV

SIGNAL

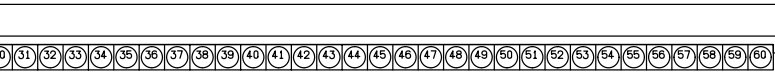
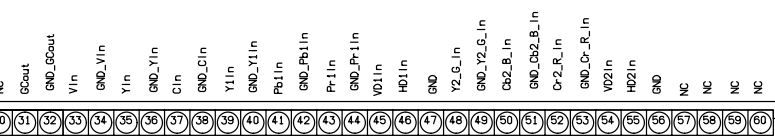

CONNECT

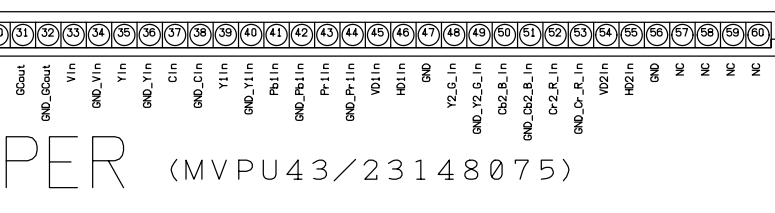
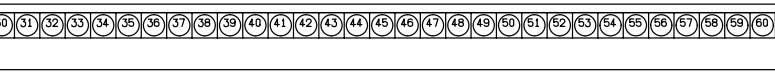

PER (MVPU43/23148075)

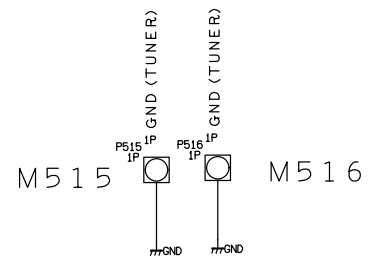

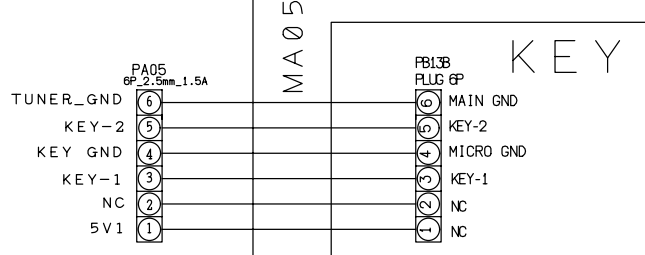
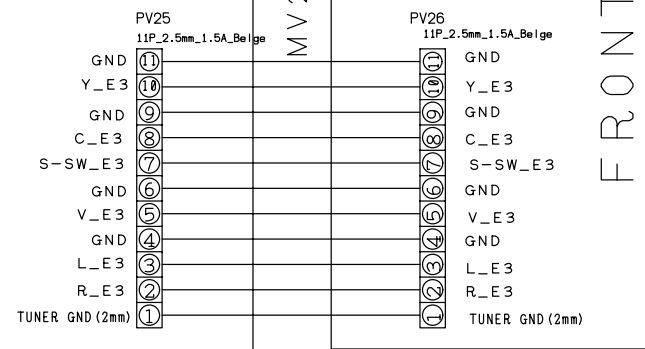
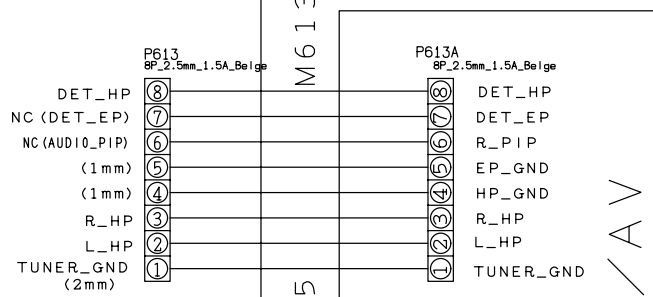
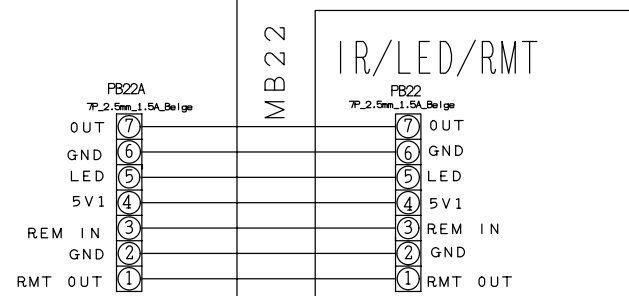
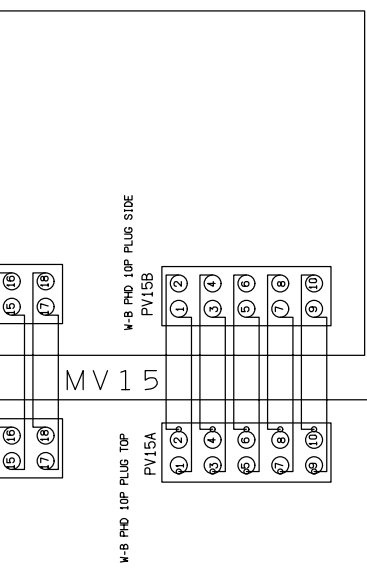

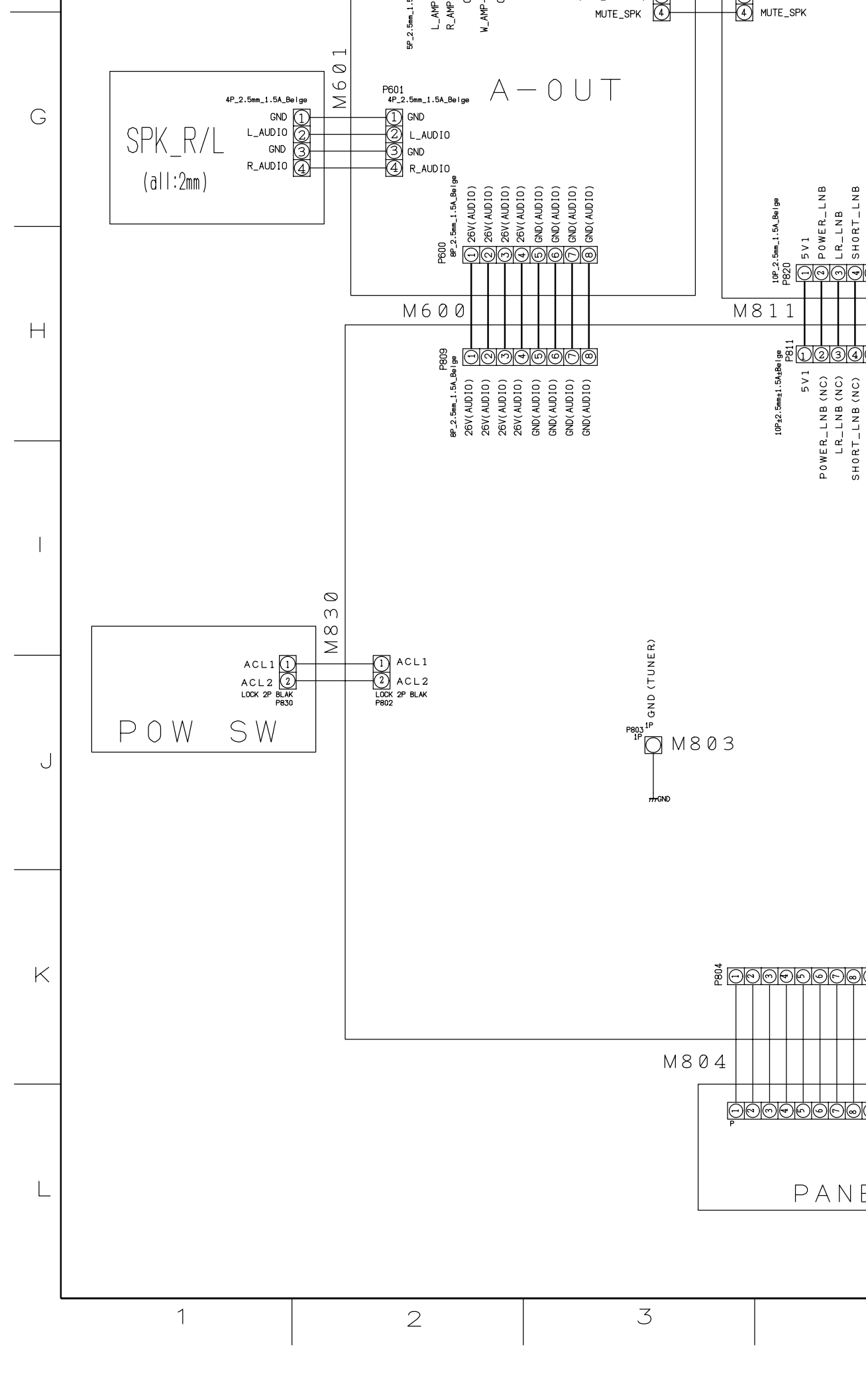

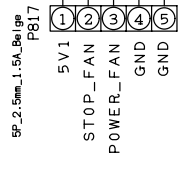
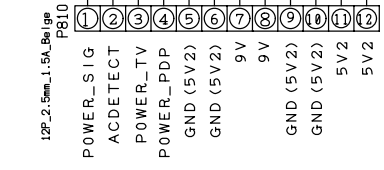
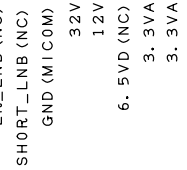
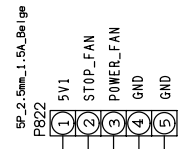
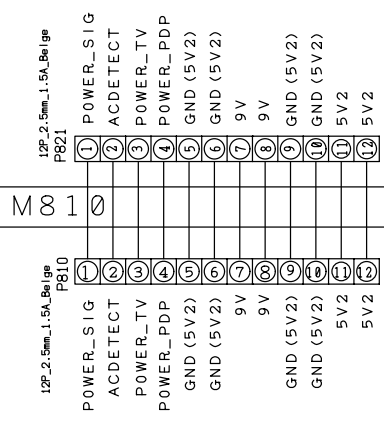
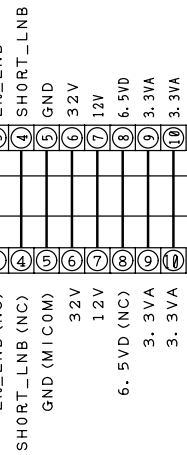

MAIN POWER

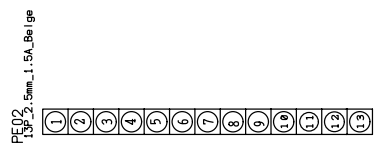
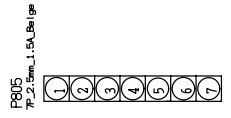
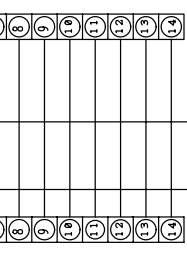

SCALER
M805

DB

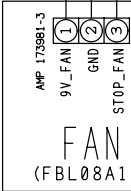
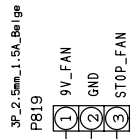

M819

FAN
(FBL08A12)

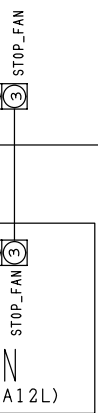
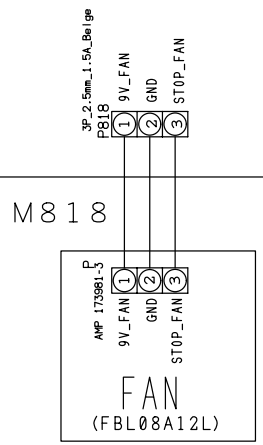
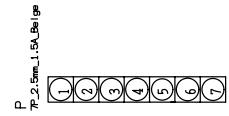
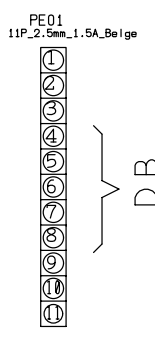
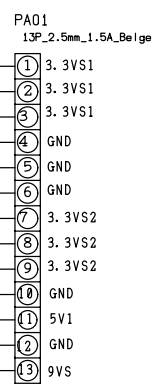
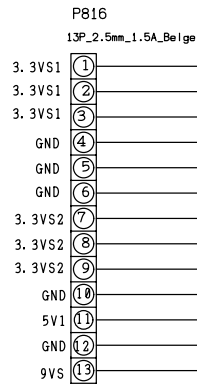
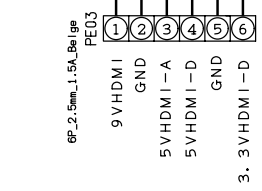
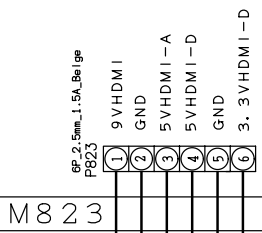

- 40 RMT_IN
- 39 GND
- 38 KEY_1
- 37 GND
- 36 KEY_2
- 35 GND
- 34 NC(YS_TEXT)
- 33 GND
- 32 POWER_SIG
- 31 GND
- 30 NC(SM_TX)
- 29 GND
- 28 NC(SM_LRX)
- 27 ACDETECT
- 26 STOP_FAN
- 25 NC
- 24 POWER_PDP
- 23 KVD
- 22 SYNC_M
- 21 MUTE_E
- 20 RMT_OUT
- 19 V_PIP_MC
- 18 V_AV_MC
- 17 ACP
- 16 LED
- 15 POWER_TV
- 14 SPM
- 13 MUTE_A
- 12 SYNC_S
- 11 GND
- 10 VD_OSD
- 9 HD_OSD
- 8 SCL1

LOWB

SCALER

POWER

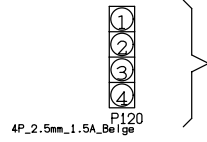

For GEMSTAR EPG

SCL1
SDA1
POWER_FAN
GND
AFT1
AFT2
HYP_RST
RESET

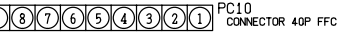

P
DF17C(3.0H)-60DS-0.5V



PF01
DF17C(3.0H)-60DS-0.5V



SCL0
GND
+5V-1
SDA0
P113
5P_2.5mm_1.5A_BeIge

PA01
PLUG 7P

RESET2
VDD(5V)
TD0
GND
TCLK
VDD
TD1



G

H

I

J

K

L

26HL83
WIRING CONNECTION DIAGRAM

3

14

15

16